



CENTER FOR RESEARCH AND ADVANCED STUDIES
OF THE NATIONAL POLYTECHNIC INSTITUTE

Campus Zacatenco

Department of Mathematics

Arithmetical structures and applications of determinantal ideals of graphs

A DISSERTATION PRESENTED BY

Ralihe Raúl Villagrán Olivas

TO OBTAIN THE DEGREE OF

DOCTOR IN SCIENCE

IN THE SPECIALITY OF MATHEMATICS

Thesis Advisors:

Dr. Carlos Enrique Valencia Oleta

Dr. Carlos Alejandro Alfaro Montúfar



CENTRO DE INVESTIGACIÓN Y DE ESTUDIOS AVANZADOS
DEL INSTITUTO POLITÉCNICO NACIONAL

Unidad Zacatenco

Departamento de Matemáticas

Estructuras aritméticas y aplicaciones de ideales determinantales de gráficas

TESIS QUE PRESENTA

Ralihe Raúl Villagrán Olivas

PARA OBTENER EL GRADO DE

DOCTOR EN CIENCIAS

EN LA ESPECIALIDAD DE MATEMÁTICAS

Directores de Tesis:

Dr. Carlos Enrique Valencia Oleta

Dr. Carlos Alejandro Alfaro Montúfar

To my daughter, Amelia.

Mathematics knows no races or geographic boundaries; for mathematics, the cultural world is one country.

–DAVID HILBERT

We (he and Halmos) share a philosophy about linear algebra: we think basis-free, we write basis-free, but when the chips are down we close the office door and compute with matrices like fury.

–IRVING KAPLANSKY

Every hard problem in mathematics has something to do with combinatorics.

–LENNART CARLESON

Abstract

In this thesis we study two topics. The first concerns to arithmetical structures of a (multidi)graph (without loops), and the second is about the determinantal ideals (specifically critical and characteristic ideals) of a graph. The Laplacian matrix of a (multidi)graph G is defined as $L(G) = D(G) - A(G)$ where $A(G)$ is the adjacency matrix of G and $D(G)$ its (out-)degree matrix. The sandpile (also known as critical) group of G , denoted by $K(G)$, is the torsion part of the cokernel of $L(G)$ and the cokernel of $A(G)$ is called the Smith group of G . The pseudo-Laplacian of G and $\mathbf{d} \in \mathbb{Z}^{V(G)}$ is the matrix

$$L(G, \mathbf{d}) = \text{Diag}(\mathbf{d}) - A(G),$$

Note that $L(G, \mathbf{deg}_G)$ is the Laplacian matrix. Moreover, if we replace \mathbf{d} for the tuple of indeterminates indexed by the vertices of G , $X_G = (x_1, x_2, \dots, x_n)$. Then $L(G, X_G)$ is called the generalized Laplacian of G . Let $G = (V, E)$ be a multidigraph. An arithmetical structure of G is a pair of vectors with positive integer entries $(\mathbf{d}, \mathbf{r}) \in \mathbb{N}_+^V$, such that the entries of \mathbf{r} have no common factor and $L(G, \mathbf{d})\mathbf{r}^t = \mathbf{0}^t$. Similarly, we can define the arithmetical structures of integer matrices.

We analyze the relation between finding arithmetical structures of non-negative and the positivity of its minors. We give an algorithm that computes all the arithmetical structures and discuss the link between this algorithm and Hilbert's tenth problem. In order to build our algorithm, we introduce a new class of Z -matrices, the Quasi M -matrices. Furthermore, the ideas developed to solve the problem for the equation over multidigraphs is generalized to a bigger class of polynomials that we call dominated polynomials. In particular, the concept of arithmetical structure is generalized to this new framework and we describe an algorithm to find the arithmetical structures of dominated polynomials.

Another focus of this thesis is to understand the connection between the algebraic and combinatorial properties of determinantal ideals of graphs, that is, the determinantal ideals of $L(G, X_G)$. As well as the application of such results. For instance, with help of the study of the critical ideals of the weak dual of outerplanar graphs we determine the algebraic structure of the sandpile groups of such graphs, and we can extend these methods to compute the sandpile groups of many other families of planar graphs. Moreover, we compute the identity element of the sandpile group of the dual graph of several outerplanar graphs.

On the other hand, we analyze the concept of characteristic ideals. Let $\mathcal{K}_{\leq k}$ be the family of connected simple graphs which sandpile group has at most k invariant factors equal to 1 and let $\mathcal{S}_{\leq k}$ be the family of connected simple graphs whose adjacency matrix has at most k invariant factors equal to 1. We characterize the graphs with one, two and three trivial characteristic ideals. In consequence, we characterize the regular graphs in $\mathcal{K}_{\leq k}$ for $k \leq 3$. We give a simpler alternative way to characterize this families of graphs. Finally, we also present a list of 43 forbidden graphs for $\mathcal{S}_{\leq 4}$.

Las matemáticas no conocen razas ni fronteras geográficas; para las matemáticas, el mundo cultural es un solo país.

–DAVID HILBERT

Nosotros (Halmos y él) compartimos una filosofía con respecto al álgebra lineal: pensamos sin bases, escribimos sin depender de bases, pero cuando las cosas se ponen especialmente difíciles cerramos la puerta de la oficina y calculamos con matrices con gran ímpetu.

–IRVING KAPLANSKY

Todo problema difícil en matemáticas tiene algo que ver con la combinatoria.

–LENNART CARLESON

Resumen

En esta tesis estudiamos dos temas. El primero concierne a las estructuras aritméticas de una multidigráfica (sin lazos), y el segundo a los ideales determinantaes (específicamente ideales críticos y característicos) de una gráfica. La matriz Laplaciana de una (multidi)gráfica G se define como $L(G) = D(G) - A(G)$ donde $A(G)$ es la matriz de adyacencia de G y $D(G)$ su matriz de grados (exteriores). El grupo crítico de G , denotado por $K(G)$, es la parte de torsión del cokernel de $L(G)$ y el cokernel de $A(G)$ es llamado el grupo de Smith de G . La matriz pseudo-Laplaciana de G y $\mathbf{d} \in \mathbb{Z}^{V(G)}$ es la matriz

$$L(G, \mathbf{d}) = \text{Diag}(\mathbf{d}) - A(G),$$

Note que $L(G, \mathbf{deg}_G)$ es la matriz Laplaciana. Además si sustituimos \mathbf{d} por la tupla de variables indeterminadas indexadas por los vertices de G , $X_G = (x_1, x_2, \dots, x_n)$. Entonces a $L(G, X_G)$ la llamamos la Laplaciana generalizada de G . Sea $G = (V, E)$ una multidigráfica. Una estructura aritmética de G es una dupla de vectores con entradas enteras positivas $(\mathbf{d}, \mathbf{r}) \in \mathbb{N}_+^V$, tales que las entradas de \mathbf{r} no comparten un factor en común y $L(G, \mathbf{d})\mathbf{r}^t = \mathbf{0}^t$. Similarmente, podemos definir las estructuras aritméticas de matrices enteras.

Analizamos la relación entre encontrar estructuras aritméticas de matrices enteras no-negativas y la positividad de sus menores. Describimos un algoritmo que calcula todas las estructuras aritméticas y estudiamos la relación entre este algoritmo y el décimo problema de Hilbert. Para construir nuestro algoritmo, introducimos una nueva clase de Z -matrices, las cuasi M -matrices. Además, las ideas desarrolladas para solucionar el problema sobre la ecuación de multidigráficas son generalizadas a una clase más amplia de polinomios, los cuales llamamos polinomios dominados. En particular, el concepto de estructura aritmética se generaliza en este nuevo marco y se describe un algoritmo para encontrar las estructuras aritméticas de polinomios dominados.

Otro enfoque de la tesis es entender la conexión entre las propiedades algebraicas y combinatorias de los ideales determinantaes de gráficas, es decir los ideales determinantaes de $L(G, X_G)$. Así como las aplicaciones de estos resultados. Por ejemplo, con la ayuda del estudio de los ideales críticos de la gráfica dual débil de gráficas “outerplanares” determinamos la estructura algebraica de los grupos críticos de dichas gráficas, y podemos extender estos métodos para calcular los grupos críticos de muchas otras familias de gráficas planares. Más aún, calculamos el elemento identidad del grupo crítico de la gráfica dual de varias gráficas outerplanares.

Por otro lado, analizamos el concepto de ideales característicos. Sea $\mathcal{K}_{\leq k}$ la familia de gráficas simples conexas que tienen grupo crítico con a lo más k factores invariantes a 1 y sea $\mathcal{S}_{\leq k}$ la familia de gráficas simples conexas cuya matriz de adjacencia tiene a lo más k factores invariantes iguales a 1. Describimos la caracterización de las gráficas con uno, dos y tres ideales característicos triviales, y en consecuencia la caracterización de gráficas regulares en $\mathcal{K}_{\leq k}$ para $k \leq 3$. Damos una manera alternativa mas simple de caracterizar estas familias de gráficas. Por último, presentamos una lista de 43 gráficas prohibidas para $\mathcal{S}_{\leq 4}$.

Agradecimientos

Primero, quiero agradecer a mis asesores; Carlos Alfaro y Carlos Valencia, por su gran apoyo durante la realización de este proyecto. Así como por las incontables horas de charla matemática y consejos. Agradezco profundamente sus enseñanzas, las cuales se complementaron de manera excelente.

Agradezco mucho a mis coautores por permitirme incluir en esta tesis trabajo realizado en conjunto. Me gustaría extender mi agradecimiento al personal administrativo del CINVESTAV, por su amabilidad y por mantener las dificultades de la burocracia al mínimo.

Agradezco a mis sinodales, Ruy Fabila, Criel Merino, Yuriko Pitones y Rafael Villarreal por el valioso tiempo que dedicaron a la revisión de esta tesis.

Agradezco al Consejo Nacional de Ciencia y Tecnología (CONACYT) por el apoyo económico que me otorgó durante la realización de mis estudios de doctorado.

En lo personal, quiero agradecer a Irene, mi compañera de vida, por su enorme apoyo y amor que ha demostrado durante todo este tiempo. Gracias a ti y Amelia, la motivación nunca fue un problema.

Agradezco a mi Mamá, Liliana, a mi Papá, Raúl, y a mis hermanos, Ángel y Kevin; por su apoyo incondicional e incansable que hace parecer cualquier cosa posible.

Por último quisiera disculparme con quien haya dejado fuera de éstos agradecimientos o que no haya mencionado por nombre. Esta tesis y mi doctorado en general han sido un esfuerzo en equipo y reconozco el privilegio y suerte que he tenido por contar con el apoyo de tantas personas en el proceso. Muchas gracias a todos.

Contents

1. Introduction	1
2. Preliminaries	11
2.1. Graph theory	11
2.2. The sandpile group and the Smith group	16
2.3. Chip-firing	19
2.4. Arithmetical structures of graphs	20
2.5. M-matrices	22
2.6. Critical and characteristic ideals of graphs	24
3. Algorithmic aspects of Arithmetical Structures on Matrices	31
3.1. Arithmetical Structures of non-negative matrices	33
3.2. Quasi M-matrices	35
3.3. The algorithm	38
4. Arithmetical Structures of Dominated Polynomials	49
4.1. Motivation	50
4.2. Dominated polynomials	53
4.3. An algorithm for the polynomial case	55
4.4. Integer solutions of dominated polynomials	61
5. Sandpile groups of outerplanar graphs	67
5.1. Sandpile groups of planar graphs	69
5.2. Sandpile groups of outerplanar graphs	73
5.3. Outerplane graphs whose weak dual is a path	76
5.4. Outerplane graphs whose weak dual is a starlike tree	78
5.5. Identity element of the sandpile group of outerplanar graphs	80
6. Graphs with few characteristic ideals	87
6.1. Characteristic ideals of graphs	89
6.2. Regular graphs with at most 3 trivial characteristic ideals	94
6.3. Graphs whose Smith group has at most 4 invariant factors equal to 1	100

Conclusions	105
Bibliography	107
Index of symbols	115
Index	117

Introduction

This thesis approaches two themes. The first one is arithmetical structures. Concept that was introduced for simple graphs in the context of arithmetic geometry in [71]. We analyze the connection of this concept with the theory of non-negative matrices, in particular the connection with the properties of M -matrices. We introduce the quasi M -matrices. Then we present an algorithm that computes the arithmetical structures for a square integer matrix with non-negative entries. One can find these arithmetical structures of matrices based on the properties of some polynomials related to determinants arising from these matrices. In this manner, we generalize the concept of arithmetical structures to a wider family of polynomials that does not arise from graphs nor matrices naturally.

The second focus of this thesis is applying our understanding of the connection between the algebraic and combinatorial properties of determinantal ideals of graphs. In particular we describe the sandpile groups of outerplanar graphs.

Also, by determining the family of graphs with few characteristic ideals, we find the family of regular graphs with few trivial invariant factors in their sandpile groups.

It is important to mention that these two themes share some background which is covered in chapter 2, together with the rest of the preliminary theory that we consider pertinent for this thesis. However let us mention that the main common ground of this thesis is the analyzes of graph matrices. In particular, we care about the Laplacian (adjacency) matrix of a graph and the relationship between their combinatorial and algebraic properties.

Given a multidigraph $G = (V, E)$, its *generalized Laplacian* matrix is given by

$$L(G, X_G)_{u,v} = \begin{cases} x_u & \text{if } u = v, \\ -m_{u,v} & \text{if } u \neq v. \end{cases}$$

where $m_{u,v}$ is the number of arcs from the vertex u to the vertex v and

$$X_G = \{x_u \mid u \in V(G)\}$$

is a set of undetermined variables indexed by the vertices of G .

The *pseudo-Laplacian* matrix of G and $\mathbf{d} \in \mathbb{Z}_+^{|V|}$ is the matrix

$$L(G, \mathbf{d}) = \text{Diag}(\mathbf{d}) - A(G),$$

where $A(G)$ is the adjacency matrix of G and $\text{Diag}(\mathbf{d})$ is the diagonal matrix with diagonal entries corresponding to the entries of \mathbf{d} . When $\mathbf{d} = \mathbf{deg}_G$ is the out degree vector of G , then $L(G, \mathbf{deg}_G)$ is its Laplacian matrix.

Arithmetical Structures

Before describing the content of each chapter in the Arithmetical Structures part of the thesis, namely chapter 3 and 4. We summarize some of the main definitions and results that are used thereof.

Let $\mathbb{M}_n(\mathbb{Z})$ be the set of all square $n \times n$ integer matrices and let $L \in \mathbb{M}_n(\mathbb{Z})$ be a non-negative matrix with all its diagonal entries equal to zero, then the pair (\mathbf{d}, \mathbf{r}) (of positive integer vectors of length n) is called an *arithmetical structure* of L if

$$(\text{Diag}(\mathbf{d}) - L)\mathbf{r}^t = \mathbf{0}^t \text{ and } \gcd(r_1, \dots, r_n) = 1$$

We denote the set of arithmetical structures of L as $\mathcal{A}(L)$. We impose the condition of primitiveness $\gcd(r_1, \dots, r_n) = 1$ on vector \mathbf{r} because $(\text{Diag}(\mathbf{d}) - L)\mathbf{r}^t = \mathbf{0}^t$ implies that $(\text{Diag}(\mathbf{d}) - L)c\mathbf{r}^t = \mathbf{0}^t$ for all $c > 0$. If every row of L has some non-zero entry. Then L has a canonical arithmetical structure, namely $(\mathbf{1}L^t, \mathbf{1})$. Actually $\mathcal{A}(L) \neq \emptyset$ if and only if L has no row with all entries equal to zero.

The concept of arithmetical structure was first introduced for (simple) graphs, that is, for the adjacency matrices of graphs by D. Lorenzini in [71] as some intersection matrices that arise in the study of degenerating curves in algebraic geometry. We denote the set of arithmetical structures of a multidigraph G as,

$$\mathcal{A}(G) = \mathcal{A}(A(G)) \text{ where } A(G) \text{ is the adjacency matrix of } G$$

Arithmetical structures were further studied on square non-negative integer matrices in [42]. We can think of non-negative integer matrices as the adjacency matrices of multidigraphs or directed weighted graphs.

It is important to recall that the set of arithmetical structures on a simple connected graph is finite [71, Lemma 1.6]. This result is generalized in [42] as follows.

Theorem 1.1 (3.1.2). *Let L be a non-negative matrix with zero diagonal such that $\mathcal{A}(L) \neq \emptyset$. Then $\mathcal{A}(L)$ is finite if and only if L is irreducible.*

Let us recall that a matrix A is called reducible if A is similar via a permutation to a block upper triangular matrix. We say that A is irreducible when is not reducible. Equivalently, when A is the adjacency matrix of a digraph, A is irreducible if and only if the digraph associated to A is strongly connected, see [55].

Hence, by the characterization of the finiteness of the arithmetical structures, it is natural to ask for an algorithm that computes them.

Question 1.2. *There exists an algorithm that compute arithmetical structures of an integer non-negative matrix with zero diagonal?*

In chapter 3 we had analyzed the relation between finding arithmetical structures of non-negative integer matrices and the positivity of its minors. We answer Question 1.2 positively by finding an algorithm that computes all of its arithmetical structure.

In section 3.1 we recall some theory about M -matrices and their relationship with arithmetical structures. Moreover, in section 3.2, we introduce and study the class of *quasi M -matrices*. In particular we introduced the concept of quasi non-singular M -matrices which generalizes *almost non-singular M -matrices*, see [42]. An almost non-singular M -matrix is a Z -matrix such that all its proper principal minors are positive and its determinant is non-negative. A quasi non-singular M -matrix is a Z -matrix whose every proper principal minors are positive. But unlike M -matrices and almost non-singular M -matrices its determinant is not necessarily non-negative. Moreover, we will establish some properties of these matrices that help us find the algorithm and prove its correctness. Perhaps the most important result in this section is the monotonicity of the determinant of quasi non-singular M -matrices. Let $A = (a_{ij})$ and $B = (b_{ij})$ be two real matrices of size $m \times n$, we say that $A \geq B$ if $a_{ij} \geq b_{ij}$ for every $i = 1, \dots, m$ and $j = 1, \dots, n$. Moreover we write that $A > B$ if $A \geq B$ and $A \neq B$.

Theorem 1.3 (3.2.4). *If M is a real Z -matrix, then M is a quasi non-singular M -matrix if and only if*

$$\det(M + D) > \det(M + D') > \det(M)$$

for every diagonal matrices such that $D > D' > 0$.

Let A be a Z -matrix. Then A is called an almost non-singular M -matrix if all of its proper principal minors are positive and its determinant is non-negative. Now, let

$$\mathcal{D}_{\geq 0}(L) = \{\mathbf{d} \in \mathbb{N}_+^n \mid (\text{Diag}(\mathbf{d}) - L) \text{ is an almost non-singular } M\text{-matrix}\},$$

where L is a square integer non-negative matrix L with zero diagonal. By Dickson's lemma the set of minimal elements $\min \mathcal{D}_{\geq 0}(L)$ of $\mathcal{D}_{\geq 0}(L)$ is finite.

In section 3.3 we present the algorithm 3.3.3 that computes $\min \mathcal{D}_{\geq 0}(L)$.

Theorem 1.4 (3.3.4). *Algorithm 3.3.3 computes the set $\min \mathcal{D}_{\geq 0}(L)$ for any given non-negative matrix L with zero diagonal.*

By using this algorithm as a subroutine we get a second algorithm that computes the arithmetical structures on L .

Corollary 1.5 (3.3.6). *Algorithm 3.3.5 computes the set of arithmetical structures on any non-negative square matrix L with diagonal zero.*

We use the algorithm developed in this work to present some computational evidence for the following conjecture.

Conjecture 1.6. [42, Conjecture 6.10] *Let G be a simple graph with n vertices, then*

$$\left| \mathcal{A}(P_n) \right| \leq \left| \mathcal{A}(G) \right| \leq \left| \mathcal{A}(K_n) \right|,$$

where P_n and K_n are the path and the complete graph on n vertices respectively.

In chapter 4, we start with section 4.1, by setting the relation between this algorithm and Hilbert's tenth problem (HTP). HTP asked for an algorithm to determine whether any given polynomial Diophantine equation has a solution in integers. After important preliminary work by Martin Davis, Hilary Putnam and Julia Robinson, Yuri Matiyasevic showed in 1970 that no such algorithm exists (see [74]). Before this there were some efforts to build this type of algorithms for some little families of polynomial Diophantine equations, we readdress this approach for a subset of monic, free-square polynomial Diophantine equations.

On the other hand, note that if (\mathbf{d}, \mathbf{r}) is an arithmetical structure of A , then \mathbf{d} is a solution of the Diophantine equation

$$f_L(X) = \det(\text{Diag}(X) - L) = 0. \quad (1.1)$$

However, the converse is false. Meaning that not all solution is part of an arithmetical structure. The smaller simple graph where we can find such solution is the path with five vertices. Nevertheless the algorithm provides a way of finding these different positive solutions. Moreover, it is known that there are methods such that by finding all positive solutions to a Diophantine equation we can know all of the integer solutions [45]. Therefore we may say that a version of Hilbert's tenth problem for polynomials of this form is solved.

In section 4.2 we generalize the concept of (d -)arithmetical structure for a class of polynomials we call *dominated polynomials*. A polynomial is dominated if every non-leading monomial is a factor of the leading monomial. We claim that this property is the main one that characterizes the behaviour of the determinantal equation 1.1.

Definition 1.7 (4.2.2). *Let $f \in \mathbb{Z}[X]$ be an irreducible square-free dominated polynomial with its leading coefficient positive. An arithmetical structure of f is a vector $\mathbf{d} \in \mathbb{N}_+^n$ such that $f(\mathbf{d}) = 0$ and all the non-constant coefficients of $f_{\mathbf{d}}(X)$ are positive.*

It is important to note that there are dominated polynomials that are not represented by the determinant of such sort of integer matrix.

Definition 1.8. *Given a square-free dominated polynomial f on n variables, let*

$$\mathcal{D}(f) = \{ \mathbf{d} \in \mathbb{N}_+^n \mid \mathbf{d} \text{ is an arithmetical structure of } f \}$$

and

$$\mathcal{D}_{\geq 0}(f) = \left\{ \mathbf{d} \in \mathbb{N}_+^n \mid \text{all non-constant coefficients of } f_{\mathbf{d}}(X) \text{ positive and } f(\mathbf{d}) \geq 0 \right\}.$$

In section 4.3 we generalize the ideas developed to solve the problem over matrices are generalized to the class dominated polynomials. Leading to an algorithm (3.3.3) that computes the arithmetical structures of dominated polynomials.

Theorem 1.9 (4.3.6). *Algorithm 4.3.1 computes the sets $\min\mathcal{D}_{\geq 0}(f)$ and $\mathcal{D}(f)$ for any square-free dominated polynomial $f \in \mathbb{Z}[X]^*$.*

In section 4.4 we will approach Hilbert's tenth problem for the dominated polynomials. With respect to this, we will explore the limitations of the algorithm with several examples.

Applications of Determinantal ideals of graphs

Let M and N be two $n \times n$ matrices with integer entries. We say that M and N are *equivalent*, denoted by $N \sim M$, if there exist $P, Q \in GL_n(\mathbb{Z})$ such that $N = PMQ$. Given a square integer matrix M , the *Smith normal form* (SNF) of M is the unique equivalent diagonal matrix $\text{Diag}(d_1, d_2, \dots, d_n)$ whose non-zero entries are non-negative and satisfy d_i divides d_{i+1} . The diagonal elements of the SNF are known as *invariant factors*. In [88], Stanley surveys the influence of the SNF in combinatorics. Recently, in [1], some evidence that the invariant factors of some graph matrices could be a finer invariant to distinguish graphs in cases where other algebraic invariants, such as the spectrum fail, was presented.

In our context the SNF is relevant since the *sandpile group* is isomorphic to the torsion part of the cokernel of the Laplacian matrix of G [66, Chapter 4], and the SNF of a matrix is a standard technique to determine the structure of cokernel. This is because if $N \sim M$, then $\text{coker}(M) = \mathbb{Z}^n/\text{Im}M \cong \mathbb{Z}^n/\text{Im}N = \text{coker}(N)$. In particular, the fundamental theorem of finitely generated Abelian groups states

$$\text{coker}(M) \cong \mathbb{Z}_{d_1} \oplus \mathbb{Z}_{d_2} \oplus \dots \oplus \mathbb{Z}_{d_r} \oplus \mathbb{Z}^{n-r},$$

where r is the rank of M . The minimal number of generators of the torsion part of the cokernel of M equals the number of positive invariant factors of $\text{SNF}(M)$.

Henceforth let G be a simple graph. The cokernel of the adjacency matrix $A(G)$ is known as the *Smith group* of G and is denoted $S(G)$, and as mentioned above the torsion part of the cokernel of the Laplacian matrix $L(G)$ is known as the *sandpile group* $K(G)$ of G . Smith groups were introduced in [84]. Recently, the computation of the Smith group for several families of graphs has attracted attention, see [20, 32, 48, 49, 95]. The sandpile group is especially interesting for connected graphs, since its order is equal to the number of spanning trees of the graph. The sandpile group has been studied intensively over the last 30 years on several contexts: the *group of components* [72, 73], the *Picard group* [17, 26], the *Jacobian group* [17, 26], the *sandpile group* [9, 39], *chip-firing game* [26, 75], or *Laplacian unimodular equivalence* [56, 76].

The book of Klivans [66] is an excellent reference on the theory of sandpile groups. In said book many generalizations are studied, such as Sandpile groups for M -matrices, cell complexes, etc. For simplicial complexes on a sphere, it is mentioned in [44] that the sandpile groups encode combinatorial structure not determined by the homology groups.

Let $\mathcal{K}_{\leq k}$ be the family of simple connected graphs having sandpile group with at most k invariant factors equal to 1 and let $\mathcal{S}_{\leq k}$ denote the family of simple connected

graphs whose adjacency matrix has at most k invariant factors equal to 1. Moreover, let \mathcal{K}_k be the family of simple connected graphs having sandpile group with exactly k invariant factors equal to 1. The first result related to these families of graphs appeared when D. Lorenzini noticed in [72], and independently A. Vince in [92], that the graphs in \mathcal{K}_1 consist only of complete graphs. After, C. Merino in [75] posed interest on the characterization of \mathcal{K}_2 and \mathcal{K}_3 . In this sense, some advances have been done. For instance, in [79] the graphs in \mathcal{K}_2 whose third invariant factor is equal to n , $n - 1$, $n - 2$, or $n - 3$ were characterized. In [59] the characterizations of the graphs in \mathcal{K}_2 with a cut vertex and number of independent cycles equal to $n - 2$ are given.

Let $\text{rank}(M)$ denote the rank of M , that is, the dimension of the image space of M and let $[n] = \{1, 2, \dots, n\}$. The following result is convenient in many situations to compute the invariant factors of a matrix M .

Theorem 1.10 (2.2.1). *For $k \in [\text{rank}(M)]$, let $\Delta_k(M)$ be the gcd of the k -minors of matrix M , and $\Delta_0(M) = 1$. Then the k -th invariant factor $d_k(M)$ of M equals*

$$\frac{\Delta_k(M)}{\Delta_{k-1}(M)}.$$

This theorem motivated the definition of critical ideals of graphs by H. Corrales and C. Valencia in [40]. These ideals are determinantal ideals generalizing the sandpile group and their varieties generalize the spectrum of the graph. Moreover, in [2] we can see that the determinantal ideals can be used to distinguish graphs in cases where the spectrum and even the SNF fail.

Definition 1.0.1. *Given a graph G with n vertices and $1 \leq i \leq n$, let*

$$I_i(G, X_G) = \langle \text{minors}_i(L(G, X_G)) \rangle \subseteq \mathcal{P}[X_G]$$

be the i -th critical ideal of G .

The evaluation of the k -th critical ideal of G at $X = \text{deg}(G)$ will be an ideal in \mathbb{Z} generated by $\Delta_k(L(G))$. Also notice that in general the critical ideals depend on the base ring \mathcal{P} , however we are mainly interested on the case when $\mathcal{P} = \mathbb{Z}$. Furthermore, although we shall focus on simple graphs. These determinantal ideals can be defined for more general graphs, they have been carefully studied for signed and directed graphs for instance.

The following is an important invariant in this context

Definition 1.11. *Let $G = (V, E)$ be a graph. The algebraic co-rank, denoted by $\gamma(G)$ of G is the maximum integer i such that $I_i(G, X_G)$ is trivial.*

Note that $\langle 0 \rangle \subsetneq I_n(G, X_G) \subseteq \dots \subseteq I_1(G, X_G) \subseteq \langle 1 \rangle$. Moreover, for every H induced subgraph of G we have that $I_i(H, X_H) \subseteq I_i(G, X_G)$ for all $1 \leq i \leq |V(H)|$, and in consequence $\gamma(G) \leq \gamma(H)$.

By the study of the critical ideals and algebraic co-rank of graphs a complete characterization of \mathcal{K}_2 was obtained in [10]. On the other hand, the characterization of the graphs in \mathcal{K}_3 seems to be a hard open problem [11].

In chapter 5 we will show a new application of the critical ideals for computing the sandpile group of *planar graph*.

The *reduced Laplacian matrix* $L_k(G)$ for a connected graph G is the $(n-1) \times (n-1)$ matrix obtained by deleting the row and column k from $L(G)$.

We will use G^* to denote the *dual* of a plane graph G , and the *weak dual*, denoted by G_* , is constructed the same way as the dual graph, but without placing the vertex associated with the outer face. It is known [25, 39, 92] that the sandpile group of a planar graph is isomorphic to the sandpile group of its dual. Since the dual of any plane graph is connected [28], then $K(G) \cong \text{coker}(L_k(G^*))$ and $\tau(G) = \det(L_k(G^*))$, where $\tau(G)$ is the number of spanning trees of G .

In [81], C. Phifer gave a nice interpretation of this relation by introducing the *cycle-intersection matrix* of a plane graph as follows. Given a plane graph G with s interior faces F_1, \dots, F_s , let $c(F_i)$ denote the length of the cycle which bounds interior face F_i . We define the *cycle-intersection matrix*, $C(G) = (c_{ij})$ to be a symmetric matrix of size $s \times s$, where $c_{ii} = c(F_i)$, and c_{ij} is the negative of the number of common edges in the cycles bounding the interior faces F_i and F_j , for $i \neq j$. Note that $C(G)$ is the reduced Laplacian of G^* where the column and row associated with the outer face are removed from $L(G^*)$. Therefore we have the following.

Lemma 1.12 (5.0.2). *Let G be a plane graph. Then*

$$K(G) \cong \text{coker}(C(G)) \text{ and } \tau(G) = \det(C(G)).$$

Recently, the structure of the sandpile group of some subfamilies of the *outerplanar* graphs were established, see for example [22, 33, 67]. Also, the Tutte polynomial and the number of spanning trees of an infinite families of outerplanar, small-world and self-similar graphs were obtained in [38, 70]. Despite this, the algebraic structure of the sandpile groups of the outerplanar graphs have been largely unknown.

Chapter 5 is organized as follows; In Section 5.1, we explore the relation obtained in Lemma 5.0.2 under the lenses of the critical ideals of graphs. Then, we show a methodology to compute the algebraic structure of the sandpile groups of the plane graph family \mathcal{F} that have a common weak dual. This method consists in evaluating the indeterminates of the critical ideals of the weak dual at the lengths of the cycles bounding the interior faces of the plane graph in \mathcal{F} . In Section 5.2, we use this method and the property that the weak dual of outerplane graphs are trees, which was suggested by Chen and Mohar in [33], to compute the sandpile groups of outerplanar graphs. We will give a description of the sandpile group of an outerplanar graph G in terms of the associated weak dual tree T and the 2-matchings of the graph T^l , where T^l is the graph obtained from T by adding a loop at each vertex of T .

A 2-matching is a set of edges $\mathcal{M} \subseteq E(G)$ such that every vertex of G is incident to at most two edges in \mathcal{M} and note that a loop counts as two incidences for its respective vertex. The set of 2-matchings of T^l with k edges is denoted by ${}_2\text{Mat}(T^l, k)$. Given a 2-matching \mathcal{M} of T^l , let $\ell(\mathcal{M})$ be the loops of \mathcal{M} . A 2-matching \mathcal{M} of T^l is *minimal* if there does not exist a 2-matching \mathcal{M}' of T^l such that $\ell(\mathcal{M}') \subsetneq \ell(\mathcal{M})$ and $|\mathcal{M}'| = |\mathcal{M}|$. The set of minimal 2-matchings of T^l will be denoted by ${}_2\text{Mat}^*(T^l)$, and the set of

minimal 2-matchings of T^l with k edges will be denoted by ${}_2\text{Mat}_k^*(T^l)$. Let $d_X(\ell(\mathcal{M}))$ denote $\det(C(G)[V(\ell(\mathcal{M}))]) = \det((\text{Diag}(c(F_1), \dots, c(F_s)) - A(T))[V(\ell(\mathcal{M}))])$, that is, the determinant of the submatrix of $\text{Diag}(c(F_1), \dots, c(F_s)) - A(T)$ formed by selecting the columns and rows associated with the loops of \mathcal{M} .

Then the sandpile groups of outerplanar graphs are determined in terms of the length of the cycles bounding the interior faces of their outerplane embeddings and the 2-matching of the weak dual with loops.

Theorem 1.13 (5.2.5). *Let G be a biconnected outerplane graph with F_1, \dots, F_n interior faces and whose weak dual is the tree T with n vertices. Let*

$$\Delta_k = \gcd(\{d_X(\ell(\mathcal{M})) : \mathcal{M} \in {}_2\text{Mat}_k^*(T^l)\}),$$

for $k \in [n]$. Then $K(G) \cong \mathbb{Z}_{\Delta_1} \oplus \mathbb{Z}_{\frac{\Delta_2}{\Delta_1}} \oplus \dots \oplus \mathbb{Z}_{\frac{\Delta_n}{\Delta_{n-1}}}$ and $\tau(G) = \Delta_n$.

This result rely on previous results obtained by Corrales and Valencia in [40]. In sections 5.3 and 5.4 we specialize the main result to *polygon chains* and *polygon flowers* respectively. Finally, in Section 5.5, we compute the identity configuration for the sandpile groups of the dual graphs of many outerplane graphs.

In chapter 6 we use the determinantal ideals of graph to approach the characterization of $\mathcal{K}_{\leq k}$.

In section 6.1, we introduce the concept of *characteristic ideals* which are determinantal ideals defined in [40] as a generalization of the sandpile group and the *characteristic polynomial*. Also, we present the characterization of the graphs with one and two trivial characteristic ideals, and by product the characterization of the regular graphs in $\mathcal{K}_{\leq 1}$ and $\mathcal{K}_{\leq 2}$. The characterization of graphs with 3 trivial characteristic ideals is given in Section 6.2.

Theorem 1.14 (6.2.7). *A connected graph G is in $\mathcal{C}_{\leq 3}$ if and only if it is an induced subgraph of C_5 , or of a complete 4-partite graph, or an induced subgraph of one of the following:*

- (1) *the triangular prism:*

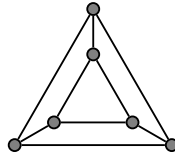

- (2) $C_4^{\mathbf{r}}$, for some \mathbf{r} such that $-\mathbf{r} \in \mathbb{N}^4$:

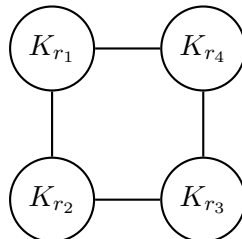

(5) $S_4^{\mathbf{r}}$, for some \mathbf{r} such that $-\mathbf{r} \in \mathbb{N}^4$:

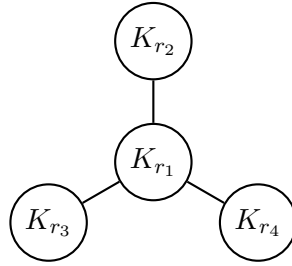

Consequently, this theorem leads to a complete characterization of regular graphs in $\mathcal{K}_{\leq 3}$.

Corollary 1.15 (6.2.8). *Let G be a connected simple regular graph. Then $G \in \mathcal{K}_{\leq 3}$ if and only if G is one of the following:*

- (a) C_5 ,
- (b) the triangular prism:

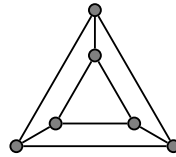

- (c) a complete graph K_r ,
- (d) a regular complete bipartite graph $K_{r,r}$,
- (e) a regular complete tripartite graph $K_{r,r,r}$,
- (f) a regular complete graph 4-partite graph $K_{r,r,r,r}$,
- (g) $C_4^{(-r,-r,-r,-r)}$, for any $r \in \mathbb{N}$.

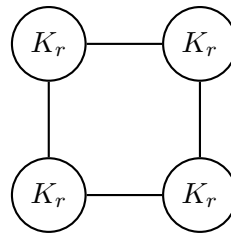

The characterization of $\mathcal{S}_{<1}$, $\mathcal{S}_{<2}$, and $\mathcal{S}_{<3}$ can be derived from the obtained results, however, in Section 6.3, we show an alternative and simpler way to characterize these graph families. We also present a list of 43 forbidden graphs for $\mathcal{S}_{\leq 4}$.

Summarizing the content of each of the following chapters: In chapter 2 we recapitulate the theory of some of the concept used in this thesis. In chapter 3 we present

an algorithm to compute the arithmetical structures of square integer non-negative matrices with zero diagonal, this chapter is based on the preprint [90]. In chapter 4 we explore the concept of arithmetical structures for some polynomials which are not described by the determinant of some matrix with indeterminate diagonal entries. Precisely for dominated polynomials. All this leads to an algorithm that computes arithmetical structures of dominated polynomials. This chapter is based on the preprint [90]. In chapter 5 we use the critical ideals of the weak dual graphs of outerplanar graphs to describe their sandpile groups. Also, this method can be used for many other planar graphs homeomorphic to outerplanar graphs. Finally, we compute the recurrent configurations associated with the identity element of the sandpile group of the dual graph of an outerplane graph. This chapter is based on the article [14]. In chapter 6 we use the characteristic ideals to approach the problem of characterizing $\mathcal{K}_{\leq 3}$. In particular we find the family of regular graphs in $\mathcal{K}_{\leq 3}$ by characterizing the graphs with at most three trivial characteristic ideals. We also show an alternative and simpler way to obtain the characterization of $\mathcal{S}_{\leq 3}$, and a list of minimal forbidden graphs for $\mathcal{S}_{\leq 4}$. This chapter is based on the article [5].

Preliminaries

First, we make a short overview of the diverse concepts needed to establish the framework of the problems studied in the next sections and follow their solutions. We start with some basic graph theory.

2.1. Graph theory

Definition 2.1.1. *A graph is a pair $G = (V, E)$ where V is a finite set and E is a finite collection of non-ordered pairs of elements of V . We call the elements of V vertices, and the elements of E are called edges. Moreover, the order of G is its number vertices $|V|$, and $|E|$ is called the size of G .*

Let $G = (V, E)$ be a graph and $(x, y) \in E$, the vertices $x, y \in V$ are called ends of the edge (x, y) ; if $x = y$, (x, y) is called a *loop*. We say that two vertices $x, y \in V$ are *adjacent* if $(x, y) \in E$. To the number of edges that has a vertex x as an end is called the degree of x and denoted by $d(x)$ or $d_G(x)$. Moreover, suppose that $V = \{v_1, v_2, \dots, v_n\}$ then $(d(v_1), d(v_2), \dots, d(v_n))$ is called the *degree vector* of G , denoted by \mathbf{deg}_G . We will write $V(G)$ and $E(G)$ denoting the vertices and edges of a graph G respectively.

Example 2.1.2. *We can use a drawing of the graph for its description, for example if $G = (V, E)$ is the graph where*

$$V = \{v_1, v_2, v_3, v_4, v_5, v_6, v_7\}$$

and

$$E = \{(v_1, v_2), (v_1, v_4), (v_1, v_5), (v_2, v_3), (v_3, v_4), (v_4, v_5), (v_6, v_2), (v_6, v_3), (v_6, v_5), (v_6, v_7)\}.$$

Then the following is a drawing of the graph G

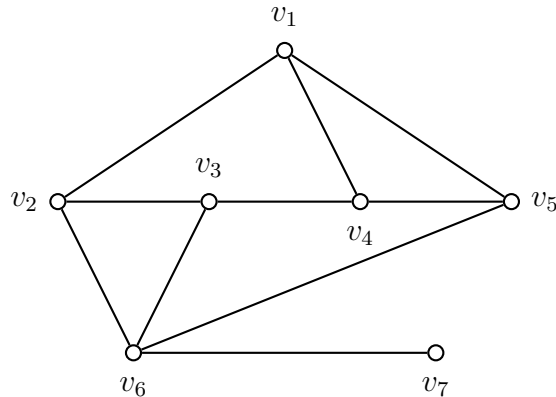

Note that a pair of vertices can have multiple edges, so for $x, y \in V$ is useful to denote the number of edges between them by $m_{x,y}$. We call G a simple graph if it has no loops neither multiple edges. A *directed graph* is a pair $G(V, \vec{E})$, where V is the finite set of vertices of G and \vec{E} is an ordered set of *directed* edges. We may say that a graph is an *undirected graph*. If we set an order for the edges of an undirected graph G , we call the resulting graph an *orientation* of G . If a graph (V, E) is also equipped with a function f that evaluates every edge into a positive real number, then (V, E, f) is called a *weighted graph*. On the other hand, if $f : E \rightarrow \{-1, +1\}$ then (V, E, f) is called a *signed graph*.

From now on with graph we refer to simple graphs unless contrary is stated, and we will use the prefix “multi” to indicate that a (multi)graph may have multiple edges. The graph G of order n that contains all possible edges is called the complete graph, denoted by K_n .

A *matching* of a graph G is a set of edges μ such that no pair of edges in μ share a vertex. If every vertex of G is incident to some edge in a matching μ , then μ is said to be a *perfect matching*. A *walk* of length k in G is an alternating sequence of vertices and edges

$$W = \{v_1, e_1, v_2, \dots, v_n, e_k, v_{k+1}\}$$

where $e_i = (v_i, v_{i+1})$. Then we can also denote a walk by its subsequence sequence of vertices. If $v_1 = v_{k+1}$, the walk W is called a closed walk. A *cycle* is a closed walk with every other pair of vertices distinct with each other. A *path* is a walk with all its vertices distinct. The graph that consists only of a cycle of length n is called a cycle graph and its denoted by C_n . Similarly, the graph consisting only of a path of length $n - 1$ is called the path graph and its denoted by P_n . We say that a graph is connected if for every pair of vertices $u, v \in G$ there is a path from u to v . If G is not connected, we say G is disconnected. A graph without cycles is called a forest and a connected forest is called a tree. A vertex of degree one in a tree is called a leaf. Whilst the tree of order n consisting of a vertex of degree $n - 1$ and $n - 1$ leaves is called a star and is denoted by S_n . The distance from a given vertex u to another vertex V in a graph G is the length of the smallest path from u to v , denoted by $d_G(u, v)$.

Let \mathbb{Z} and \mathbb{N} denote the set of all integer numbers and the set of integer numbers greater or equal to zero, respectively. Also, let \mathbb{N}_+ be the set of positive integers.. The following are a few useful definitions

Definition 2.1.3. Let $G = (V, E)$ be a graph, G is called r -regular ($r \in \mathbb{N}$) if every vertex of G has degree equal to r .

Definition 2.1.4. Let $G = (V, E)$ be a graph, we define the complement graph of G , denoted by \overline{G} , as the graph with

$$V(\overline{G}) = V(G) \text{ and } E(\overline{G}) = (V(G) \times V(G)) \setminus E(G)$$

Definition 2.1.5. Let $G = (V, E)$ be a graph, we define the cone graph of G , denoted by $c(G)$, as the graph with

$$V(c(G)) = V \cup \{u\} \text{ and } E(c(G)) = E \cup \{(u, v) \mid v \in V\}$$

Definition 2.1.6. Let G and H be graphs whose sets of vertices are disjoint. Then the disjoint union of such graphs, denoted by $G + H$, is defined as follows

$$V(G + H) = V(G) \cup V(H) \text{ and } E(G + H) = E(G) \cup E(H).$$

Definition 2.1.7. Let G and H be graphs whose sets of vertices are disjoint, then the join of these graphs, denoted by $G \vee H$, is the graph defined by

$$V(G \vee H) = V(G) \cup V(H) \text{ and } E(G \vee H) = E(G + H) \cup \{(v, u) \mid v \in V(G), u \in V(H)\}.$$

Given a graph $G = (V, E)$, an *independent* or *stable set* S of vertices for G is a subset of V such that G has no edges in $S \times S$. Now, let K_{m_1, m_2, \dots, m_k} denote the complete multipartite graph, that is, the graph consisting of k independent sets $\{S_1, \dots, S_k\}$, each with m_i vertices respectively, such that any given vertex in S_i is adjacent with every vertex in S_j for every $j \neq i$. For a given positive integer $k \geq 4$, we may call its corresponding complete multipartite graph simply k -partite. Also, bipartite or tripartite for $k = 2, 3$ respectively.

Let G and H be two graphs. If $V(H) \subseteq V(G)$ and $E(H) \subseteq E(G)$, then H is called a *subgraph* of G . If $V(H) = V(G)$ then H is called an *spanning subgraph* of G .

Definition 2.1.8. Let H be a subgraph of G . Then H is called an *induced subgraph* of G if $E(H) = (V(H) \times V(H)) \cap E(G)$.

Let H be an induced subgraph of G . If H is a complete graph, then H is called a *clique* of G .

Let \mathcal{F} be a family of graphs, we define $\text{Forb}(\mathcal{F})$ as all the graphs G such that H is not an induced subgraph of G for every $H \in \mathcal{F}$. That is, the family of graphs with forbidden induced set \mathcal{F} . Many interesting families of graphs can be describe in this manner. For instance, *threshold graphs* can be describe as $\text{Forb}(\{P_4, C_4, 2K_2\})$ and *Perfect graphs* are precisely the family $\text{Forb}(\mathcal{F})$ for \mathcal{F} being the set of all C_{2k+1} and all $\overline{C_{2k+1}}$ with $k \geq 2$.

Definition 2.1.9. *Let G be a graph. We say that G is planar if it can be drawn in the plane \mathbb{R}^2 in such a way that no pair of edges intersect each other. Moreover, we call such drawing a plane drawing of G or simply a plane graph.*

The *edge contraction* operation on a graph G occurs in a particular edge, say $e = (u, v) \in E(G)$. The resulting graph is denoted by G/e and consists on

$$V(G/e) = (V(G) \setminus \{u, v\}) \cup \{w\}$$

and

$$E(G/e) = E(G \setminus \{u, v\}) \cup \{(w, x) \mid x \in N_G(u) \cup N_G(v), u \neq x \neq v\}.$$

We say that a graph H is a *minor* of G if H can be obtained from G by deleting vertices, deleting edges, or contracting edges in G .

A subdivision of an edge consists of repeatedly adding a vertex to the interior of the edge. A *subdivision* of a graph is obtained by a sequence of subdivisions of its edges. We say that H is a topological minor of G if there exists a subgraph of G that is isomorphic to a subdivision of H .

Kuratowski's Theorem gives a characterizations of planar graphs in terms of forbidden minors.

Theorem 2.1.10. *[47, section 4.4] Let G be a graph. Then G is planar if and only if G contains neither K_5 nor $K_{3,3}$ as a minor (or equivalently, as a topological minor).*

Given a plane graph G , then the plane its divided in a finite number of regions bounded by G . This regions are called the *faces* of G and the only face of infinite area is called the outer face (we may refer to the other faces as inner faces). Let $F(G)$ be the set of faces of the plane graph G . We have that

Theorem 2.1.11. *[47, Euler's formula, Theorem 4.2.9] Let G be a connected plane graph, then*

$$|V(G)| - |E(G)| + |F(G)| = 2.$$

Remind that a graph is k -connected ($k \in \mathbb{N}$) if $|G| \geq k+1$ and $G - X$ is connected for every X such that $|X| \leq k-1$. In other words, no two vertices of G are separated by fewer than k other vertices. A 2-connected graph is also call a biconnected graph.

Proposition 2.1.12. *[47, Proposition 4.2.6] In a biconnected plane graph every face is bounded by a cycle.*

Now we define the concept of *outerplanar graphs*

Definition 2.1.13. *Let G be a graph. We say that G is outerplanar if it has a plane graph drawing in which every vertex lies on the boundary of the outer face. Moreover, we call such drawing an outerplane drawing of G or simply an outerplane graph.*

Note that G is outerplanar if and only if it contains neither a K_4 nor a $K_{2,3}$ as a minor. Next define the plane dual

Definition 2.1.14. Given a plane graph G . Then the plane dual of G denoted by G^* , is the graph formed by placing a new vertex inside each face of G and linking these new vertices, as follows: for every edge e of G we link the two new vertices in the faces incident with e by an edge e^* crossing e ; if e is incident with only one face, we attach a loop e^* to the new vertex in that face, again crossing the edge e .

In fact G^* is generally a multigraph and $G = (G^*)^*$ for every plane graph G . We may refer to the plane dual as the dual of G when the context is clear. The *weak dual* of a plane graph G , denoted by G_* is obtained from the dual by removing the vertex corresponding to the outer face.

Now, let us define the adjacency and incidence matrix of a graph. Let G be a multidigraph of order n . Then the *adjacency matrix* of G , denoted by $A(G)$, is defined by

$$A(G)_{u,v} = \begin{cases} m_{u,v} & \text{if } u \neq v, \\ 0 & \text{if } u = v. \end{cases}$$

where $m_{u,v}$ is the number of directed edges from u to v . On the other hand we define the *incidence matrix* of a multidigraph G , denoted by $B(G)$, as follows

$$B(G)_{v,e} = \begin{cases} 1 & \text{if } e = (x, v) \text{ for some } x \in V, \\ -1 & \text{if } e = (v, x) \text{ for some } x \in V, \\ 0 & \text{otherwise.} \end{cases}$$

If G is a simple graph, then

$$B(G)_{v,e} = \begin{cases} 1 & \text{if } v \in e, \\ 0 & \text{if } u \notin v. \end{cases}$$

Moreover, now we present the *Laplacian matrix* of a graph

Definition 2.1.15. Let $G = (V, E)$ be a multidigraph of order n , we define the *Laplacian matrix* of G , denoted by $L(G)$, as follows

$$L(G)_{u,v} = \begin{cases} d_G(x) & \text{if } u = v, \\ -m_{u,v} & \text{if } u \neq v. \end{cases}$$

note that $L(G)$ is a square matrix with integer entries.

The Laplacian of a multidigraph can be describe as

$$L(G) = \text{Diag}(\mathbf{deg}_G) - A(G).$$

Also note, that if G is a simple graph and D is an orientation of G , then

$$L(G) = B(D)B(D)^t.$$

Hence $L(G)$ has rank $n - c$ where c is the number of connected components of G . There are important combinatorial properties that can be abstracted from the properties of these matrices, the next result is the well known matrix-tree theorem

Theorem 2.1.16. [55, Lemma 13.2.4] *Let G be a connected graph of order n . Then if*

$$\lambda_1 \geq \lambda_2 \geq \cdots \geq \lambda_{n-1} > \lambda_n = 0$$

are the eigenvalues of $L(G)$, then the number of spanning trees of G is

$$\frac{\lambda_1 \cdots \lambda_{n-1}}{n}.$$

There are many other matrices arising from graphs (*graph matrices*) and their properties. Many of these matrices are well known and studied like the *distance matrix*, the *signless, normalized and distance Laplacian*, amongst others.

Given a square $n \times n$ real non-symmetric matrix M , then the *underlying graph* of M , denoted by $\mathcal{G}(M)$, is the directed graph of order n such that the i -th and the j -th vertices (v_i and v_j respectively) form the arc (v_i, v_j) if and only if $M_{ij} \neq 0$. If M is symmetric, then $\mathcal{G}(M)$, is the simple graph of order n such that (v_i, v_j) is an edge if and only if $M_{ij} \neq 0$.

Conversely, given a directed graph $G = (V, E)$ of order n (without multiple arcs neither loops), we define the set of matrices M such that $G = \mathcal{G}(M)$ as

$$\mathbb{M}(G) = \{M \in \mathbb{M}_n(\mathbb{R}) : M_{ij} \neq 0 \text{ if } (v_i, v_j) \in E(G) \text{ and } M_{ij} = 0 \text{ if } (v_i, v_j) \notin E(G)\}.$$

We can generalize this concept for any ring with identity R as follows

$$\mathbb{M}(G, R) = \{M \in \mathbb{M}_n(R) : M_{ij} \neq 0 \text{ if } (v_i, v_j) \in E(G) \text{ and } M_{ij} = 0 \text{ if } (v_i, v_j) \notin E(G)\}.$$

In this sense $\mathbb{M}(G) = \mathbb{M}(G, \mathbb{R})$. Also note that $A(G), L(G) \in \mathbb{M}(G, \mathbb{Z})$.

Graph matrices have been intensively studied, let us list a few references on this matter [19, 30, 31, 36, 55]. Also, for more information on graph theory in general we refer the reader to [27, 28, 47].

2.2. The sandpile group and the Smith group

In this section we to introduce the ideas and concepts of algebraic graph theory that are use on this work assuming some knowledge of abstract algebra.

Let M and N be two $n \times n$ matrices with integer entries. We say that M and N are *equivalent*, denoted by $N \sim M$, if there exist $P, Q \in GL_n(\mathbb{Z})$ such that $N = PMQ$.

Given a matrix $L \in \mathbb{M}_n(\mathbb{Z})$, the cokernel of L , denoted by $\text{coker}(L)$, is defined as

$$\text{coker}(L) = \mathbb{Z}^n / \text{Im}(L^t).$$

Since \mathbb{Z} is a Bézout domain, L is equivalent to a unique diagonal matrix

$$D = \text{Diag}(d_1, \dots, d_k, 0, \dots, 0) \text{ with } d_i \in \mathbb{N}_+, i = 1, \dots, k \text{ and } d_i | d_j \text{ for all } i \leq j.$$

Let $U, V \in GL_n(\mathbb{Z})$ such that $ULV = D$, since V is invertible $U(L\mathbb{Z}^n) = D\mathbb{Z}^n$, and since U is invertible then

$$\text{coker}(L) \cong \text{coker}(D),$$

Therefore, as the fundamental theorem of finitely generated Abelian groups states, the cokernel of L can be described as: $\text{coker}(L) \cong \mathbb{Z}_{d_1} \oplus \mathbb{Z}_{d_2} \oplus \cdots \oplus \mathbb{Z}_{d_r} \oplus \mathbb{Z}^{n-r}$.

The unique diagonal matrix D is called the *Smith Normal Form* (SNF) of L . Moreover, the elements d_1, \dots, d_k are called the *invariant factors* of L .

Another way to compute the SNF of a matrix L is by means of elementary row and column operations over the integers. That is, M can be transformed to N by applying elementary row and column operations which are invertible over the ring of integers:

1. Swapping any two rows or any two columns.
2. Adding integer multiples of one row/column to another row/column.
3. Multiplying any row/column by ± 1 .

On the other hand, we understand for r -minor the determinant of an r -square submatrix. Let

$$\text{minors}_i(L)$$

denote the set of i -minors of the matrix L . Then the Smith Normal Form

$$\text{Diag}(d_1, \dots, d_k, 0, \dots, 0)$$

of L is characterized by

Theorem 2.2.1. [62, Theorem 3.9] *Let L be an integer matrix of rank k with d_1, \dots, d_r its invariant factors. For $1 \leq r \leq k$, let $\Delta_r = \gcd(\text{minors}_i(L))$ and $\Delta_0 = 1$. Then*

$$d_r = \frac{\Delta_r}{\Delta_{r-1}}$$

This is known as the theorem of elementary divisors. Now we define the sandpile group (also known as the critical group) of a graph

Definition 2.2.2. *Let $G = (V, E)$ be a connected graph with n vertices, then the sandpile group, denoted by $K(G)$, of G is torsion part of the cokernel of the Laplacian matrix $L(G)$, that is*

$$\mathbb{Z}^n / \text{Im}L(G)^t = \mathbb{Z} \oplus K(G)$$

Since $L(G)$ has rank $n - 1$ the Smith normal form of $L(G)$ has the form

$$\text{Diag}(d_1, d_2, \dots, d_{n-1}, 0), \text{ and } K(G) \cong \mathbb{Z}_{d_1} \oplus \cdots \oplus \mathbb{Z}_{d_{n-1}}.$$

The integers d_1, \dots, d_{n-1} may also be called *invariant factors* of $K(G)$. Since \mathbb{Z}_1 is the trivial group, if $d_k = 1$ for some $k = 1, \dots, n - 1$ then, we say that $K(G)$

has at least k *trivial invariant factors* and if $d_{k+1} \neq 1$ then, we say that $K(G)$ has exactly k trivial invariant factors. In this way the Smith normal form characterizes the algebraic structure of the sandpile group. In [88], Stanley surveys the influence of the SNF in combinatorics. Recently, in [1], evidence was found that the invariant factors of the distance Laplacian and the distance signless Laplacian matrices could be a finer invariant to distinguish graphs in cases where other algebraic invariants, such as those derived from the spectrum do fail. Thus confirming what was suggested by Biggs [26].

The following is an important known result which derives from 2.1.16.

Theorem 2.2.3. *If G is a connected graph, then $K(G)$ has order equal to the number of spanning trees of G , denoted by $\tau(G)$.*

The sandpile group has been studied for several families of graphs. For instance, $K(C_n) = \mathbb{Z}_n$ and $K(K_n) = (\mathbb{Z}_n)^{n-2}$. Also, for trees [68, 89], threshold graphs [35], line graphs [23, 69, 80], product graphs [61, 76] and graphical elliptic curves [77]. In general, characterizing the structure of sandpile groups seems to be a difficult problem.

The book of Klivans [66] is an excellent reference on the theory of sandpile groups. Several generalizations are studied therein, such as Sandpile groups for M -matrices, cell complexes, etc. It is pointed out in [44] that the sandpile groups of simplicial complexes drawn on a d -dimensional sphere encode combinatorial structure not determined by their homology groups.

At the beginning of the study of sandpile groups, it was found [73, 93] that many graphs have a cyclic sandpile group from which was conjectured that almost all graphs have cyclic sandpile group. However, it was found in [96] that the probability that the sandpile group of a *random graph* is cyclic is asymptotically at most

$$\zeta(3)^{-1}\zeta(5)^{-1}\zeta(7)^{-1}\zeta(9)^{-1}\zeta(11)^{-1}\dots \approx 0.7935212,$$

where ζ is the *Riemann zeta function*; differing from Wagner's conjecture. Still, it was proved [34] that for any given connected simple graph, there is a homeomorphic graph with cyclic sandpile group. We say that two graphs G_1 and G_2 are in the same *homeomorphism class* if there exists a graph G that is a subdivision of both G_1 and G_2 .

Another couple of relevant results related with planar graphs, both of which can be found in [39], are the following

Theorem 2.2.4. *Let G be a planar graph and let G^* be any of its dual graphs. Then $K(G)$ and $K(G^*)$ are isomorphic groups.*

Theorem 2.2.5. *Every finite abelian group is the sandpile group of some planar graph.*

On the other hand, we could focus our attention to the invariant factors of the adjacency matrix of a graph.

Definition 2.2.6. Let G be a graph. The Smith group of G is the cokernel of its adjacency matrix $A(G)$ and is denoted by $S(G)$.

Therefore if r is the rank of $A(G)$ and f_1, f_2, \dots, f_r are its invariant factors, then $S(G) \cong \mathbb{Z}_{f_1} \oplus \dots \oplus \mathbb{Z}_{f_r}$. For instance $S(K_n) = \mathbb{Z}_{n-1}$. Note that not every element in the Smith group needs to be a torsion element. For example, note that for $n \geq 3$

$$S(C_n) = \begin{cases} \mathbb{Z}^2 & \text{if } n \equiv 0 \pmod{4}, \\ \mathbb{Z}_2 & \text{if } n \equiv \pm 1 \pmod{4}, \\ (\mathbb{Z}_2)^2 & \text{if } n \equiv 2 \pmod{4}. \end{cases}$$

and

$$S(\overline{C}_n) = \begin{cases} \mathbb{Z}_{\frac{n-3}{3}} & \text{if } n \equiv 0 \pmod{3}, \\ \mathbb{Z}_{n-3} \oplus \mathbb{Z}^2 & \text{otherwise.} \end{cases}$$

See [95] for more complex examples.

2.3. Chip-firing

The sandpile group has many different interpretations. A particularly interesting and combinatorial way of seeing it is by the *chip-firing process*. Again, we refer the reader to the book [66]. The results presented in this section can be found therein. For this section let $G = (V \cup \{s\}, E)$ be a connected simple graph of order $n + 1$. Let $s \in V$ be a distinguished vertex called *sink* and let $V = \{v_1, \dots, v_n\}$ be the other n of the vertices of G . We define the chip-firing process as follows

Definition 2.3.1.

- A *chip configuration* on G is an integer vector $\mathbf{c} = (c_1, c_2, \dots, c_n, c_{n+1})$ such that $c_i \geq 0$ for all $i = 1, \dots, n$. We can think of \mathbf{c} as a vector recording the number of chips (or grains of sand) in each vertex.
- A vertex $v \in V$ *fires* by sending one chip to each of its neighbors. This results in a new configuration $\mathbf{c}' = \mathbf{c} - L(G)^{(i)}$ where $L(G)^{(i)}$ is the row of $L(G)$ corresponding to v_i . A *legal fire* is one in which the vertex that fired satisfied that $c_v \geq \deg(v)$. In this case, we say that v is *ready to fire*.
- A configuration \mathbf{c} of G is called *stable* if no vertex is ready to fire, that is $c_v < \deg(v)$ for all $v \in V$.
- The *chip-firing process* on G starts with an initial chip configuration \mathbf{c} . At each step, a vertex in V that is ready to fire is selected and fired. Firing a vertex may cause other vertices to become ready to fire. If, at any stage, a stable configuration is reached, the process stops.

Note that all initial configurations eventually stabilize. Nevertheless, not all stable configurations have the same properties, meaning that not all of them are special. Let $\mathbf{c}_{|s} = (c_1, \dots, c_n)$. Indeed, there are many stable configurations, every configurations such that $0 \leq \mathbf{c}_{|s} < \mathbf{deg}_{G-s}$.

The stabilization of a configuration \mathbf{c} , denoted by $\text{stab}(\mathbf{c})$ is the unique stable configuration reachable from \mathbf{c} after a sequence of legal chip-firing moves.

Proposition 2.3.2. *An stable configuration of G , \mathbf{c} , is critical if*

$$\mathbf{c} = \text{stab}(\mathbf{b}) \text{ for some } \mathbf{b}_{|s} \geq \mathbf{deg}_{G-s}$$

Hence the critical configurations are precisely the configurations which we would end up after finalizing a chip-firing process that started with some a generic initial configuration.

Proposition 2.3.3. *Let \mathbf{b} and \mathbf{c} be two critical configurations of G then $\text{stab}(\mathbf{b} + \mathbf{c})$ is also a critical configuration of G .*

Therefore for any two critical configurations \mathbf{b} and \mathbf{c} , we define the sandpile sum $\mathbf{b} \oplus \mathbf{c}$ as:

$$\mathbf{b} \oplus \mathbf{c} = \text{stab}(\mathbf{b} \oplus \mathbf{c}).$$

Definition 2.3.4. *Let G be a connected graph with sink s . The sandpile group $SP(G)$ is the finite Abelian group on the set of critical configurations of G with addition operator given by the sandpile sum \oplus .*

Indeed this group is isomorphic to the torsion part of the Laplacian matrix of G , as described in previous section. Equivalently $SP(G)$ is isomorphic to the cokernel of the *reduced Laplacian* of G , that is $SP(G) \cong K(G)$. It is important to note that the algebraic structure of the sandpile group does not depend on the sink vertex, meanwhile the combinatorial structure depicted by the critical configurations of G does depend on the sink vertex.

Let $\mathbf{c}_{\max} = \mathbf{deg}_G - \mathbf{1}$ be the *maximal stable configuration*. Then

Proposition 2.3.5. *The identity element of $SP(G)$ is given by*

$$\text{stab}(2\mathbf{c}_{\max} - \text{stab}(2\mathbf{c}_{\max}))$$

2.4. Arithmetical structures of graphs

Arithmetical structures of graphs were introduced by Dino Lorenzini, see [71], in arithmetic geometry.

An integer vector \mathbf{a} is said to be *primitive* if $\gcd\{a_i\} = 1$, that is, the entries of \mathbf{a} are relatively prime. Given a graph $G = (V, E)$ of order n and given any positive integer vector \mathbf{b} , then the matrix $\text{Diag}(\mathbf{b}) - A(G)$ is called a *pseudo-Laplacian* matrix of G , usually denoted by $L(G, \mathbf{b})$. We define the arithmetical structures of a graph as follows

Definition 2.4.1. Let G be a graph of order n . Then a pair of n -vectors \mathbf{d} and \mathbf{r} with positive integer entries are an arithmetical structure of G if and only if

$$L(G, \mathbf{d})\mathbf{r}^t = \mathbf{0}^t \text{ and } \mathbf{r} \text{ is primitive.}$$

Note that any graph without isolated vertices has the *canonical arithmetical structure* $(\mathbf{deg}_G, \mathbf{1})$.

Example 2.4.2. Consider the cycle with 5 vertices and note that the following pseudo-Laplacian matrix of C_5 has rank 4

$$L(C_5, \mathbf{d}) = \begin{pmatrix} 2 & -1 & 0 & 0 & -1 \\ -1 & 1 & -1 & 0 & 0 \\ 0 & -1 & 7 & -1 & 0 \\ 0 & 0 & -1 & 2 & -1 \\ -1 & 0 & 0 & -1 & 2 \end{pmatrix}$$

The vector $\mathbf{r} = (4, 5, 1, 2, 3)$ is in the kernel of $L(C_5, \mathbf{d})$. That is

$$L(C_5, \mathbf{d})\mathbf{r}^t = \mathbf{0}^t.$$

Therefore the pair (\mathbf{d}, \mathbf{r}) is an arithmetical structure of C_5 .

Considering an arithmetical structure of a graph G we can define the sandpile group of $(G, \mathbf{d}, \mathbf{r})$ as

$$K(G, \mathbf{d}, \mathbf{r}) = \ker(\mathbf{r}^t) / \text{Im}(L(G, \mathbf{d})).$$

In the frame of arithmetic geometry, this group is called the group of components [72].

We denote the set of all arithmetical structures of G as $\mathcal{A}(G)$. We call the set of vectors $\{\mathbf{d} \mid (\mathbf{d}, \mathbf{r}) \in \mathcal{A}(G)\}$ the *d-arithmetical structures* of G and similarly $\{\mathbf{r} \mid (\mathbf{d}, \mathbf{r}) \in \mathcal{A}(G)\}$ are the *r-arithmetical structures* of G . Lorenzini proved the following result.

Theorem 2.4.3. [71] Let G be a graph. Then $\mathcal{A}(G)$ is finite if and only if G is connected.

The arithmetical structures can be described in a nice combinatorial manner, and the number $|\mathcal{A}(G)|$ is known for certain graphs. For instance, the following result can be found in [29].

Theorem 2.4.4. [29] Let $n \geq 2$ be an integer and $Cat_n = \frac{1}{n+1} \binom{2n}{n}$ be the n -th catalan number. Then

$$|\mathcal{A}(P_n)| = Cat_{n-1} \text{ and } |\mathcal{A}(C_n)| = (2n - 1) Cat_{n-1}$$

There have been some work on trying to describe the number of arithmetical structures and their sandpile groups for another graphs of small size like *bidents*, see [16], and the multigraph resulting from a simple path by doubling an edge in [54]. Another aspects of arithmetical structures have been studied. For example in [43] the arithmetical structures of a graph G with a cut vertex v are described by the arithmetical structures of the connected components of $G - v$. On the other hand, it is known that finding a tight bound on the number of arithmetical structures for connected graphs is a difficult problem. We can find an approach to this in [65].

The arithmetical structures of the complete graph are directly related with the *Egyptian fractions* which is known to be a difficult problem in number theory. In fact, the d -arithmetical structures of K_n are the vectors $\mathbf{d} \in \mathbb{N}_+^n$ such that

$$\sum_{i=1}^n \frac{1}{d_i + 1} = 1$$

Let us conclude this section with the following conjecture

Conjecture 2.4.5. [42] *Let G be a connected graph of order n . Then*

$$|\mathcal{A}(P_n)| \leq |\mathcal{A}(G)| \leq |\mathcal{A}(K_n)|.$$

2.5. M-matrices

Let M be a $n \times n$ square real matrix. Then M is a *Z-matrix* if every non-diagonal entry of M is nonpositive, that is, $M_{i,j} \leq 0$ for $i \neq j$. Notice that the pseudo-Laplacian matrices of a graph G are Z-matrices.

In the following, matrix always means square matrix. Recall that a real matrix is called non-negative if all their entries are non-negative real numbers. We recall the classical definition of a *M-matrix*.

Definition 2.5.1. *A real matrix A is said to be an M-matrix if*

$$A = \alpha I - M,$$

for some non-negative matrix M with $\alpha \geq \rho(M)$.

Where $\rho(M)$ is the spectral radius of the square matrix M and is defined by

$$\rho(M) = \max \{ |\lambda| \mid \lambda \in \sigma(M) \},$$

where $\sigma(M)$ is the spectrum of M , that is, the set of complex eigenvalues of M . It turns out that a *M-matrix* $A = \alpha - M$ is singular if and only if $\alpha = \rho(M)$. Note that the Laplacian of any connected graph G is a singular *M-matrix* of rank $|G| - 1$. The class of *M-matrices* admit many equivalent definitions, for instance Berman [24] enlists more than 80 ways to characterize *M-matrices*.

The study of M -matrices is divided in two big parts: non-singular M -matrices (see [24, Section 6.2]) and singular M -matrices (see [24, section 6.4]). An square matrix is called *singular* if its determinant is zero. Singular M -matrices have been more difficult to study than non-singular M -matrices. M -matrices are very important in a broad range of mathematical disciplines. The book by Berman and Plemmons, [24], studies non-singular and singular M -matrix. Recently M -matrices have been studied in the context of chip-firing games, see [57] and the references contained there.

For $k \in [n] := \{1, \dots, n\}$, let $\mathcal{I} = \{r_j\}_{j=1}^k$ and $\mathcal{J} = \{c_j\}_{j=1}^k$ be two sequences such that $1 \leq r_1 < r_2 < \dots < r_k \leq n$ and $1 \leq c_1 < c_2 < \dots < c_k \leq n$. Then let $A[\mathcal{I}; \mathcal{J}]$ denote the submatrix of a matrix A induced by the rows with indices in \mathcal{I} and columns with indices in \mathcal{J} . A principal submatrix is a submatrix $A[\mathcal{I}; \mathcal{J}]$ such that $\mathcal{I} = \mathcal{J}$. Moreover, the determinant of a principal submatrix is called a *principal minor* of A . We will focus on the following definition.

Definition 2.5.2. [24, Theorem 6.4.6 (A_1), page 156] *A Z-matrix A is called an M-matrix if all of its principal minors are non-negative. Furthermore an M-matrix is non-singular if and only if all of its principal minors are positive.*

Singular and non-singular M -matrices are, clearly, closely related. In particular, we have the following result

Theorem 2.5.3. [24, Lemma 4.1, section 6.] *Let A be Z-matrix. Then A is an M-matrix if and only if*

$$A + \epsilon I$$

is a non-singular M-matrix for all scalars $\epsilon > 0$.

The sandpile group of a non-singular M -matrix L , denoted by $K(L)$, is defined as the cokernel of its transpose and $|K(L)| = \det(L)$. Non-singular and singular matrices were studied in [24, Chapter 6]. M -matrices are present in a large variety of mathematical subjects, like numerical analysis, probability, economics, operations research, etc., see [24] and the references therein. The next class of M -matrices were introduced in [42].

Definition 2.5.4. *A real matrix A is called an almost non-singular M-matrix if A is a Z-matrix and all the proper principal minors are positive.*

Thus, M is an almost non-singular M -matrix of size n if and only if all of its proper sub-matrices of size $n - 1$ are non-singular M -matrices and $\det(M) \geq 0$. The main point of this section is to establish that every pseudo-Laplacian of the form $L(G, \mathbf{d})$, with \mathbf{d} a d -arithmetical structure of the connected graph G , is an almost non-singular M -matrix of rank $|G| - 1$. The class of almost non-singular M -matrices has the following characterization.

Theorem 2.5.5. [42, Theorem 2.6] *If M is a real Z-matrix, then the following conditions are equivalent:*

1. M is an almost non-singular M -matrix.

2. $M + D$ is a non-singular M -matrix for any diagonal matrix $D > 0$.
3. $\det(M) \geq 0$ and $\det(M + D) > \det(M + D') > 0$ for any diagonal matrices such that $D > D' > 0$.

The monotonicity of the determinant of an almost non-singular M -matrix is very important and motivates the concept of a quasi M -matrix, which is given in section 3.2. By using an algebraic computational system is not difficult to check whether a matrix is indeed an M -matrix or not. In particular it is interesting how to check if an specific Z -matrix is M -matrix.

Remark 2.5.6. Let M be a real Z -matrix and

$$f_M(\mathbf{x}) = \det(\text{Diag}(x_1, \dots, x_n) + M) \in \mathbb{R}[x_1, \dots, x_n].$$

Then M is an M -matrix (non-singular M -matrix) if and only if the coefficients of the polynomial f_M are non-negative (positive). In a similar way, M is an almost non-singular M -matrix if and only if all the coefficients except maybe the constant term of the polynomial f_M are positive. For instance, if

$$M = \begin{pmatrix} 1 & -1 & 0 \\ 0 & 1 & -1 \\ -1 & -1 & 2 \end{pmatrix},$$

then $f_M(\mathbf{x}) = x_1x_2x_3 + 2x_1x_2 + x_1x_3 + x_2x_3 + x_1 + 2x_2 + x_3$. Thus, M is an almost non-singular matrix M -matrix, but not a non-singular M -matrix.

This relationship between M -matrices and polynomials with certain non-negativity properties on their coefficients is further explored in chapters 3 and 4.

2.6. Critical and characteristic ideals of graphs

In this section we generalize the concept of Laplacian matrix and define some new objects called *determinantal ideals* of graphs. We assume some knowledge of the basic definitions from the theory of *Gröbner basis*, we refer the reader to [3, 15, 50].

Consider an $n \times n$ matrix M whose entries are in the polynomial ring $\mathbb{Z}[X]$ with $X = \{x_1, \dots, x_m\}$. Recall that the determinant of $M[\mathcal{I}; \mathcal{J}]$ is called k -minor of M . The set of all k -minors of M is denoted by $\text{minors}_k(M)$.

Furthermore, given a matrix $M \in \mathbb{M}(G, \mathbb{Z}[X])$ for some graph G . Then we refer to the ideal generated by the set of all k -minors of M as a *determinantal ideal* of G and its denoted by

$$I_k(M) = \langle \text{minors}_k(M) \rangle$$

An ideal is said to be *trivial* or *unit* if it is equal to $\langle 1 \rangle$, that is, the ideal is equal to $\mathbb{Z}[X]$. We will concentrate on two special type of determinantal ideals of graphs, because we will make use of them in chapters 5 and 6. Namely, the *critical* and the *characteristic ideals* of a graph.

Definition 2.6.1. Let $G = (V, E)$ be a graph with $|G| = n$, we define the generalized Laplacian matrix of G , by

$$L(G, X_G)_{u,v} = \begin{cases} x_u & \text{if } u = v, \\ -m_{u,v} & \text{if } u \neq v. \end{cases}$$

Now we define the critical ideals of a graph as well as their characteristic ideals

Definition 2.6.2. Given a graph G with n vertices, for $1 \leq i \leq n$, let

$$I_i(G, X_G) = \langle \text{minors}_i(L(G, X_G)) \rangle \subseteq P[X_G]$$

be the i -th critical ideal of G .

For simplicity, we usually represent these ideals by some of its Gröbner basis.

Definition 2.6.3. The k -th characteristic ideal $A_k(G, t)$ of a graph G is the k -th determinantal ideal of the matrix $tI_n - A(G)$, that is, the ideal

$$\langle \text{minors}_k(tI_n - A(G)) \rangle \subseteq \mathbb{Z}[t].$$

Note that $A_k(G, t) = I_k(G, (t, \dots, t))$ and that $A_{|G|}(G, t)$ is the ideal generated by the characteristic polynomial of $A(G)$.

Remark 2.6.4. Let G be a graph. Then

$$\langle 0 \rangle \subsetneq I_n(G, X_G) \subseteq I_{n-1}(G, X_G) \subseteq \dots \subseteq I_2(G, X_G) \subseteq I_1(G, X_G) \subseteq \langle 1 \rangle$$

Definition 2.6.5. Let $G = (V, E)$ be a graph. We define the algebraic co-rank of G as follows

$$\gamma(G) = \max\{i \mid I_i(G, X_G) = \langle 1 \rangle\}$$

the maximum integer i such that $I_i(G, X_G)$ is trivial. Similarly, we define the characteristic algebraic co-rank of G as

$$\gamma_A(G) = \max\{k \mid A_k(G, t) = \langle 1 \rangle\}$$

Note that $\gamma(G) \leq n - 1$, since

$$I_n(G, X_G) = \langle \det(L(G, X_G)) \rangle \neq \langle 1 \rangle.$$

The algebraic co-rank of a graph is closely related to the combinatorial properties of the graph. For instance, if H is an induced subgraph of G , then

$$I_i(H, X_H) \subseteq I_i(G, X_G) \text{ for all } 1 \leq i \leq |V(H)|,$$

therefore $\gamma(G) \leq \gamma(H)$.

Now, we show a couple of examples that illustrate the concept of critical and characteristic ideal.

Example 2.6.6. Let H be the complete graph with six vertices minus the perfect matching formed by the edges

$$M_3 = \{v_1v_4, v_2v_5, v_3v_6\} \text{ and } \mathcal{P} = \mathbb{Z}.$$

Then the following is a drawing of H ,

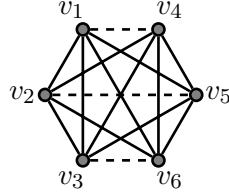

and its generalized Laplacian matrix is

$$L(H) = \begin{pmatrix} x_1 & -1 & -1 & 0 & -1 & -1 \\ -1 & x_2 & -1 & -1 & 0 & -1 \\ -1 & -1 & x_3 & -1 & -1 & 0 \\ 0 & -1 & -1 & x_4 & -1 & -1 \\ -1 & 0 & -1 & -1 & x_5 & -1 \\ -1 & -1 & 0 & -1 & -1 & x_6 \end{pmatrix}$$

By using any algebraic system, it is not difficult to see that $I_i(H, X) = \langle 1 \rangle$ for $i = 1, 2$ and for $i \geq 3$, $I_i(H, X)$ is equal to

$$\begin{cases} \langle 2, x_1, x_2, x_3, x_4, x_5, x_6 \rangle & \text{if } i = 3, \\ \langle \{x_r x_s \mid v_r v_s \in E(H)\} \cup \{2x_r + 2x_s + x_r x_s \mid v_r v_s \notin E(H)\} \rangle & \text{if } i = 4, \\ \langle \{x_k x_l (x_r + x_s + x_r x_s) \mid (r, s, k, l) \in S(H)\} \cup \{p_{(r,s,k,l)} \mid v_r v_s, v_k v_l \notin E(H)\} \rangle & \text{if } i = 5, \\ \langle x_1 x_2 x_3 x_4 x_5 x_6 - \sum_{(r,s,k,l) \in S(H)} x_r x_s x_k x_l - 2 \sum_{(r,s,k) \in T(H)} x_r x_s x_k \rangle & \text{if } i = 6, \end{cases}$$

where

$$S(H) = \{(r, s, k, l) \mid v_r v_s \notin E(H), v_k v_l \in E(H), \text{ and } \{i, j\} \cap \{k, l\} = \emptyset\},$$

$T(H)$ are the triangles of H , and

$$p_{(r,s,k,l)} = (x_r + x_s)(x_k + x_l + x_k x_l) + (x_k + x_l)(x_r + x_s + x_r x_s).$$

Note that the expressions of the critical ideals of H depend heavily on their combinatorics and note that the algebraic co-rank of H then is 2. For characteristic ideals, we can evaluate the critical ideals for $(x_1, x_2, x_3, x_4, x_5, x_6) = (t, t, t, t, t, t)$ and we have that

$$A_k(H, t) = \begin{cases} \langle 1 \rangle & \text{if } k = 1, 2, \\ \langle 2, t \rangle & \text{if } k = 3, \\ \langle 4t, t^2 \rangle & \text{if } k = 4, \\ \langle 4t^2(t+2), t^3(t+2) \rangle & \text{if } k = 5, \\ \langle t^3(t+2)^2(t-4) \rangle & \text{if } k = 6. \end{cases}$$

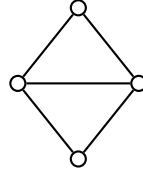

Figure 2.1: diamond graph

Example 2.6.7. Let G be the diamond graph with vertex set $V = \{v_1, v_2, v_3, v_4\}$ such that each pair of vertices are adjacent, except for v_1 and v_3 , see Figure 2.1. Then

$$tI_4 - A(G) = \begin{bmatrix} t & -1 & 0 & -1 \\ -1 & t & -1 & -1 \\ 0 & -1 & t & -1 \\ -1 & -1 & -1 & t \end{bmatrix}$$

Since ± 1 is in $\text{minors}_1(tI_4 - A(G))$ and in $\text{minors}_2(tI_4 - A(G))$, then $A_1(G, t)$ and $A_2(G, t)$ are trivial. The different 3-minors of $tI_4 - A(G)$ are:

$$t^3 - 2t, -t^2 - 2t, t^2 + t, t^3 - 3t - 2, -2t - 2.$$

Note that $t = -(-t^2 - 2t) - (t^2 + t)$, then $t \in A_3(G, t)$, and similarly $2 \in A_2(G, t)$. Since all the 3-minors are a linear combination of t and 2 , then $A_3(G, t) = \langle 2, t \rangle$. It is interesting to note that if $A_3(G, t)$ would be defined on $\mathbb{R}[t]$ instead, then $A_3(G, t)$ would be trivial. Finally, $A_4(G, t) = \langle \det(tI_4 - A(G)) \rangle = \langle t^4 - 5t^2 - 4t \rangle$. For critical ideals we have that $I_1(G, X_G) = I_2(G, X_G) = \langle 1 \rangle$. $I_3(G, X_G)$ is generated by the 10 distinct 3-minors of

$$L(G, X_G) = \begin{bmatrix} x_1 & -1 & 0 & -1 \\ -1 & x_2 & -1 & -1 \\ 0 & -1 & x_3 & -1 \\ -1 & -1 & -1 & x_4 \end{bmatrix}.$$

Namely, $-x_2 - x_3 - 2, x_1x_3 + x_1, -x_1x_2 - x_1, x_1x_2x_3 - x_1 - x_2 - x_3 - 2, x_4x_2 + x_4, -x_1x_4 - x_4 - x_1, x_4x_1x_2 - x_4 - x_1, -x_4x_3 - x_4, x_4x_2x_3 - x_4 - x_2 - x_3 - 2$ and $x_4x_1x_3 - x_4 - x_1$. Hence we can check that $\langle 2x_1 + x_2x_3x_4 \rangle$ is a Gröbner basis for $I_3(G, X_G)$. Finally the fourth critical ideal of G is generated by the determinant of its generalized Laplacian, that is

$$I_4(G, X_G) = \langle -x_2x_1 - x_3x_1 + x_2x_3x_4x_1 - x_4x_1 - 2x_1 - x_2x_3 - 2x_3 - x_3x_4 \rangle.$$

The name critical ideals was originally proposed because we can see this concept as a generalization of the critical group, that is, the sandpile group. We can see this relationship through the invariant factors of the Laplacian as follows

Proposition 2.6.8. Let G be a graph whose Laplacian matrix $L(G)$ has invariant factors d_1, d_2, \dots, d_m . Then

$$I_i(G, \text{deg}_G) = \left\langle \prod_{j=1}^m d_j \right\rangle$$

Moreover, the Smith group can be described by the characteristic ideals. Let f_1, f_2, \dots, f_n be the invariant factors of $A(G)$. Then

$$A_k(G, 0) = \left\langle \prod_{l=1}^r f_l \right\rangle.$$

The concept of determinantal ideals can be extended to other graph matrices like the distance and distance Laplacian matrices, see [8]. Therefore, for instance, the family of graphs with 2 trivial distance ideals contains the family of graphs whose distance matrix has at most two invariant factors equal to 1. In [2] we can see that the determinantal ideals can be used to distinguish graphs in cases where the spectrum and even the Smith normal form, fail.

Also the critical ideals have been studied for directed graphs. In this case, the characterization of digraphs with at most 1 invariant factor equal to 1 was completely obtained in [13]. In [6] some properties of critical ideals of signed graphs are studied.

Note that in this section we dealt with the ring of polynomials over the ring $\mathcal{P} = \mathbb{Z}$. Nevertheless critical ideals can be computed over any commutative rings with unity.

On more applications of these ideals we refer the reader to [7]. Where we can see that they turned out to be related with other known parameters, like the *minimum rank* and the *zero-forcing number*.

ARITHMETICAL STRUCTURES

Algorithmic aspects of Arithmetical Structures of Matrices

Given a non-negative integer matrix L with zero diagonal, a pair $(\mathbf{d}, \mathbf{r}) \in \mathbb{N}_+^n \times \mathbb{N}_+^n$ is called an arithmetical structure of L if

$$(\text{Diag}(\mathbf{d}) - L)\mathbf{r}^t = \mathbf{0}^t \text{ and } \gcd(r_1, \dots, r_n) = 1.$$

We impose the condition of primitiveness, $\gcd(r_1, \dots, r_n) = 1$, on the vector \mathbf{r} because $(\text{Diag}(\mathbf{d}) - L)\mathbf{r}^t = \mathbf{0}^t$ implies that $(\text{Diag}(\mathbf{d}) - L)c\mathbf{r}^t = \mathbf{0}^t$ for all $c \in \mathbb{N}_+$ and therefore any common factor in the entries of \mathbf{r} is irredundant. The set of arithmetical structures on L is denoted by $\mathcal{A}(L)$.

Arithmetical structures were first introduced for graphs, more precisely when L is the adjacency matrix of a graph, by D. Lorenzini in [71] as some intersection matrices that arise in the study of degenerating curves in algebraic geometry. For more on arithmetical structures of graphs, see chapter 2. Unless otherwise specified, L will always denote a square integer non-negative matrix of size n with zero diagonal.

It is important to recall that the set of arithmetical structures on a simple connected graph is finite. This result was generalized to non-negative matrices in [42]. Before presenting this result, let us recall that a matrix A is called reducible whenever there exists a permutation matrix P such that:

$$P^t A P = \begin{pmatrix} X & Y \\ 0 & Z \end{pmatrix}.$$

That is, A is similar via a permutation to a block upper triangular matrix. We say that A is irreducible when is not reducible. Equivalently, when A is the adjacency matrix of a digraph, A is irreducible if and only if the digraph associated to A is strongly connected, see [55].

Remark 3.0.1. *When L is a block matrix its arithmetical structures can be obtained from the arithmetical structures of its diagonal blocks. Similarly for when L is reducible.*

Since the set of arithmetical structures is finite, it is natural to ask if there exists an algorithm that computes them. We recall that it is easy to check that every vector \mathbf{d} of an arithmetical structure (\mathbf{d}, \mathbf{r}) of L is a solution of the polynomial Diophantine equation

$$f_L(X) := \det(\text{Diag}(X) - L) = 0.$$

However, its important to note that not every solution of this Diophantine equation is an arithmetical structure on L . Therefore computing arithmetical structures of a matrix consists on computing a subset of the solutions of a very special class of Diophantine equations, those whose polynomial is the determinant of a matrix with variables in the diagonal.

The main result of this chapter is that there is an algorithm that computes the arithmetical structures of an integer non-negative matrix with zero diagonal. Thus we get a set of Diophantine equations for which the tenth problem on Hilbert's has positive answer.

In section 3.1 we recall some theory about M -matrices and their relationship with arithmetical structures, see [42]. Moreover, in section 3.2, we introduce and study the class of quasi M -matrices.

Definition 3.0.2. *A real Z -matrix M is called a quasi (non-singular) M -matrix if all its proper principal minors are non-negative (positive).*

In particular we introduced the concept of quasi non-singular M -matrices. These matrices have all their proper principal minors being positive, but unlike M -matrices and almost nonsingular M -matrix its determinant is not necessarily non-negative. Moreover, we will establish some properties of these matrices that help us to find the algorithm and prove its correctness.

Now, let

$$\mathcal{D}_{\geq 0}(L) = \{\mathbf{d} \in \mathbb{N}_+^n \mid (\text{Diag}(\mathbf{d}) - L) \text{ is an almost non-singular } M\text{-matrix}\},$$

where L is a square integer non-negative matrix L with zero diagonal. By Dickson's Lemma the set of minimal elements $\min \mathcal{D}_{\geq 0}(L)$ of $\mathcal{D}_{\geq 0}(L)$ is finite.

In Section 3.3, we present an algorithm that computes $\min \mathcal{D}_{\geq 0}(L)$, see Algorithm 3.3.3. Using this algorithm as a subroutine we get a second algorithm that computes the arithmetical structures on L , see Algorithm 3.3.5.

At the end of this section we use the algorithm developed to present some computational evidence for the following conjecture. This data will give an idea of the practical complexity of the problem of compute arithmetical structures.

Conjecture 3.0.3. [42, Conjecture 6.10] *Let G be a simple graph with n vertices, then*

$$\left| \mathcal{A}(P_n) \right| \leq \left| \mathcal{A}(G) \right| \leq \left| \mathcal{A}(K_n) \right|,$$

where P_n and K_n are the path and the complete graph on n vertices respectively.

Throughout this chapter we use the *usual partial order* over \mathbb{R}^n , $n \in \mathbb{N}$. If $\mathbf{a}, \mathbf{b} \in \mathbb{R}^n$, then we say that $\mathbf{a} \leq \mathbf{b}$ if and only if $a_i \leq b_i$ for all $i = 1, \dots, n$. It is well known that this is a well partial order over \mathbb{N}^n . This is a property known as Dickson's Lemma.

Lemma 3.0.4. [46] *For any $S \in \mathbb{N}^n$ the set of minimal elements of S under the usual partial order \leq ,*

$$\min(S) = \{\mathbf{x} \in S \mid \mathbf{y} \not\leq \mathbf{x} \text{ for all } \mathbf{y} \in S \setminus \{\mathbf{x}\}\},$$

is finite.

For $\mathbf{a}, \mathbf{b} \in \mathbb{N}^n$ we say that $\mathbf{a} < \mathbf{b}$ if and only if $\mathbf{a} \leq \mathbf{b}$ and $\mathbf{a} \neq \mathbf{b}$.

3.1. Arithmetical Structures of non-negative matrices

In this section we recall the concepts of arithmetical structures and M -matrices. Henceforth we assume that by ‘‘matrix’’ we mean a square matrix of size $n \times n$ for some positive integer n unless the contrary is stated.

Given an integer non-negative matrix L with diagonal zero, let

$$\mathcal{A}(L) = \left\{ (\mathbf{d}, \mathbf{r}) \in \mathbb{N}_+^n \times \mathbb{N}_+^n \mid (\text{Diag}(\mathbf{d}) - L) \mathbf{r}^t = \mathbf{0}^t \text{ and } \mathbf{r} \text{ is primitive} \right\}$$

be the set of arithmetical structures on L . Also, let

$$\mathcal{D}(L) = \{\mathbf{d} \in \mathbb{N}_+^n \mid (\mathbf{d}, \mathbf{r}) \in \mathcal{A}(L)\} \text{ and } \mathcal{R}(L) = \{\mathbf{r} \in \mathbb{N}_+^n \mid (\mathbf{d}, \mathbf{r}) \in \mathcal{A}(L)\},$$

be the sets of d -arithmetical structures and r -arithmetical structures of L respectively.

If every entry of L is either zero or one, then $\mathcal{A}(L) = \mathcal{A}(\mathcal{G}(L))$. That is, the case of simple graphs and the case of directed graphs without multiple edges (nor loops). We can think of non-negative integer matrices in general as the adjacency matrices of multidigraphs or directed weighted graphs.

As the next result shows it is not difficult to characterize when $\mathcal{A}(L)$ is non empty.

Proposition 3.1.1. *If L is a non-negative matrix with zero diagonal, then $\mathcal{A}(L) \neq \emptyset$ if and only if L has no row with all entries equal to zero.*

Proof. (\Rightarrow) If $\mathcal{A}(L) \neq \emptyset$, then there exists $\mathbf{d}, \mathbf{r} \in \mathbb{N}_+^n$ such that $(\text{Diag}(\mathbf{d}) - L) \mathbf{r}^t = \mathbf{0}^t$. Thus $(L \mathbf{r}^t)_i = \mathbf{d}_i \mathbf{r}_i \geq 1$ for all $1 \leq i \leq n$. Moreover, since L is integer non-negative and $\mathbf{r} \geq \mathbf{1}$, then $L \mathbf{1}^t \geq \mathbf{1}^t$. That is, L has no row with all entries equal to zero.

(\Leftarrow) Since L is integer non-negative and has no row with all entries equal to zero, then $L \mathbf{1}^t \geq \mathbf{1}^t$. Thus $(\text{Diag}(L \mathbf{1}^t) - L) \mathbf{1}^t = \mathbf{0}^t$ and therefore $(\mathbf{1} L^t, \mathbf{1})$ is an arithmetical structure of L . \square

When $L\mathbf{1}^t \geq \mathbf{1}^t$ (that is, L has all its rows different to $\mathbf{0}$), the arithmetical structure $(L\mathbf{1}^t, \mathbf{1})$ is called the canonical (or trivial) arithmetical structure of L . Without loss of generality, we may write $(L\mathbf{1}^t, \mathbf{1})$ instead. In a similar way, the next result gives us a necessary and sufficient condition for the finiteness of $\mathcal{A}(L)$.

Theorem 3.1.2. [42, Theorem 3.8] *Let L be a non-negative matrix with zero diagonal such that $\mathcal{A}(L) \neq \emptyset$. Then $\mathcal{A}(L)$ is finite if and only if L is irreducible.*

Remark 3.1.3. *Note that if L is irreducible, then $-L$ and $(D - L)$ are irreducible as well, for any diagonal matrix $D > \mathbf{0}$. Also note that, in general, the last line of Theorem 3.1.2 can be equivalently stated as: Then $\mathcal{A}(L)$ is finite if and only if $\mathcal{G}(L)$ is strongly connected.*

Example 3.1.4. *By using Proposition 3.1.1 it is not difficult to check that if a digraph D has a vertex with outdegree zero, then $\mathcal{A}(A(D)) = \emptyset$. On the other hand, given any strongly connected digraph $D = (V, E)$, let D^x be the digraph given by*

$$V(D^x) = V(D) \cup \{x\} \text{ with } x \notin V(D) \text{ and } E(D^x) = E(D) \cup \{(x, y) \mid y \in V(D)\}.$$

The digraph D^x has a vertex with indegree equal to zero and is not strongly connected, therefore it has an infinite number of arithmetical structures. Note that the adjacency matrix of D^x is indeed reducible,

$$A(D^x) = \begin{pmatrix} 0 & \mathbf{1} \\ \mathbf{0} & A(D) \end{pmatrix}.$$

However, the multidigraph resulting from D^x by reverting the orientation of its arcs has none arithmetical structures.

A real matrix $M = (m_{ij})$ is called a Z-matrix if $m_{ij} \leq 0$ for all $i \neq j$. M -matrices can be defined in several ways, see [24]. Let us recall that a Z-matrix A is called an M -matrix if all of its principal minors are non-negative and A is a non-singular if and only if all of its principal minors are positive. Moreover, an M -matrix A is an almost non-singular M -matrix if all of its proper principal minors are positive. Hence, M is an almost non-singular M -matrix of size n if and only if all of its proper sub-matrices of size $n - 1$ are non-singular M -matrices and $\det(M) \geq 0$. The next result relates arithmetical structures on a matrix and M -matrices.

Theorem 3.1.5. [42, Theorem 3.2] *Let M be a Z-matrix. If there exists \mathbf{r} with all its entries positive such that $M\mathbf{r}^t = \mathbf{0}^t$, then M is an M -matrix. Moreover, M is an almost non-singular M -matrix with $\det(M) = 0$ if and only if M is irreducible and there is a vector $\mathbf{r} > \mathbf{0}$ such that $M\mathbf{r}^t = \mathbf{0}^t$.*

Therefore when M is an irreducible Z-matrix, the concept of arithmetical structure is equivalent to that of almost non-singular M -matrix. A direct consequence of Theorem 3.1.5 is the following result.

Corollary 3.1.6. [42, Corollary 3.3] *If M is an irreducible Z-matrix, then there exists \mathbf{r} with all its entries positive such that $M\mathbf{r}^t = 0$ if and only if there exists \mathbf{s} with all its entries positive such that $M^t\mathbf{s}^t = 0$.*

Thus Corollary 3.1.6 implies that if L is a non-negative matrix with zero diagonal L , then L and L^t have the same set of d -arithmetical structures, but not necessarily the same set of r -arithmetical structures. Now, let us present the next properties of almost non-singular M -matrices.

Theorem 3.1.7. [42, Theorem 2.6] *If A is a real Z-matrix, then the following conditions are equivalent:*

1. A is an almost non-singular M -matrix.
2. $A + D$ is a non-singular M -matrix for any diagonal matrix $D > 0$.
3. $\det(A) \geq 0$ and $\det(A + D) > \det(A + D') > 0$ for any diagonal matrices such that $D > D' > 0$.

The monotonicity of the determinant of an almost non-singular M -matrix is very important and motivates the concept of a quasi M -matrix, which is given next.

3.2. Quasi M-matrices

Here we will introduce the class of quasi M -matrices. This class of matrices generalizes M -matrices in a very simple way. Moreover, it has properties that will be very useful in the construction of the algorithm that computes the arithmetical structures on a matrix.

Let us recall that a real Z-matrix M is called a quasi (non-singular) M -matrix if all its proper principal minors are non-negative (positive). Then, note that M is a quasi (non-singular) M -matrix if it satisfies the condition of being an M -matrix except maybe for its determinant. That is, A is a quasi (non-singular) M -matrix of size n if all of its sub-matrices of size $(n - 1) \times (n - 1)$ are (non-singular) M -matrices.

Example 3.2.1. *Let*

$$M = \begin{pmatrix} 2 & -1 & -1 \\ 0 & 1 & -1 \\ -3 & -1 & 2 \end{pmatrix}.$$

It is not difficult to check that M is a quasi non-singular M -matrix. However, M is not an M -matrix because its determinant is equal to -4 . On the other hand

$$N = M + \begin{pmatrix} 1 & 0 & 0 \\ 0 & 0 & 0 \\ 0 & 0 & 1 \end{pmatrix} = \begin{pmatrix} 3 & -1 & -1 \\ 0 & 1 & -1 \\ -3 & -1 & 3 \end{pmatrix}$$

is an almost non-singular M -matrix with determinant equal to zero. Thus, by Theorem 3.1.7, we have that $N + D$ is a non-singular M -matrix for any positive diagonal matrix D .

Quasi M -matrices are close to be quasi non-singular M -matrices in a similar way that M -matrices are from being non-singular M -matrices. Thus the next result can be seen as a generalization of Theorem 2.5.3.

Theorem 3.2.2. *Let M be a real Z -matrix. Then M is a quasi M -matrix if and only if*

$$M + \epsilon I$$

is a quasi non-singular M -matrix for any $\epsilon > 0$.

Proof. (\Rightarrow) Let M_i be the submatrix resulting of deleting the i^{th} row and column. Since M is a quasi M -matrix we know that M_i is an M -matrix for all i . Then, by Theorem 2.5.3, every $M_i + \epsilon I_{n-1} = (M + \epsilon I)_i$ is a non-singular M -matrix for any $\epsilon > 0$, where I_{n-1} is the identity matrix of size $n - 1$. Thus, for any positive ϵ , the matrix $M + \epsilon I$ is a Z -matrix with all of its proper sub-matrices non-singular M -matrices. That is, $M + \epsilon I$ is a quasi non-singular M -matrix for any $\epsilon > 0$.

(\Leftarrow) Conversely, if $M + \epsilon I$ is a quasi non-singular M -matrix for all $\epsilon > 0$, then $(M + \epsilon I)_i$ is a non-singular M -matrix for all i and $\epsilon > 0$. Thus, by Theorem 2.5.3 M_i is an M -matrix and therefore M is a quasi M -matrix. \square

Before continuing we will fix some notation. If M is a matrix, let $g_M(X)$ be the polynomial given by $\det(\text{Diag}(X) + M)$, where X is the vector of variables (x_1, x_2, \dots, x_n) .

Proposition 3.2.3. *Let M be a square matrix of size n . Then for every $s \in [n] = \{1, \dots, n\}$ we have that*

$$g_{M_s}(X_{|s}) = \frac{\partial g_M}{\partial x_s},$$

where $X_{|s} = X \setminus \{x_s\}$ and M_s is the matrix obtained by erasing the s -th row and column from M .

Proof. Clearly, it is enough to prove the result for $s = 1$. Let $M = \text{Diag}(\mathbf{d}) - L$. Now let us note that by the minor expansion formula of the determinant

$$g_M(X) = \det(\text{Diag}(X + \mathbf{d}) - L) = (x_1 + d_1)g_{(\text{Diag}(\mathbf{d}_{|1}) - L_1)}(X_{|1}) + g(x_2, x_3, \dots, x_n)$$

for some polynomial g and where $\mathbf{d}_{|s}$ is the vector resulting from \mathbf{d} by erasing the s -th entry. Since $M_1 = (\text{Diag}(\mathbf{d}_{|1}) - L_1)$, then $\frac{\partial g_M}{\partial x_1} = g_{M_1}(X_{|1})$. \square

The next result is a key component of algorithms 3.3.3 and 3.3.5 given at next section and a generalization of Theorem 3.1.7 to quasi non-singular M -matrices.

Theorem 3.2.4. *If M is a real Z -matrix, then M is a quasi non-singular M -matrix if and only if*

$$\det(M + D) > \det(M + D') > \det(M)$$

for every diagonal matrices such that $D > D' > 0$.

Proof. Let $D > D' > 0$ be diagonal matrices and let $E_i = (e_{j,k})$ be the elementary matrix with $e_{i,i} = 1$ and $e_{j,k} = 0$ for all $(j, k) \neq (i, i)$.

(\Rightarrow) Since $M + D$ is a quasi non-singular M -matrix, then

$$\det(M_\epsilon[I; I]) = \det(M[I; I]) + \epsilon \cdot \det(M[I \setminus k; I \setminus k]) > \det(M[I; I])$$

for all $\epsilon > 0$. Thus, since $D = \sum_{i=1}^n d_i \cdot E_i$ for some $d_i \in \mathbb{R}_+$,

$$\det(M + D) > \det(M).$$

Moreover, using similar arguments it can be proven that $\det(M + D' + F) > \det(M + D')$ for any diagonal matrix $F > 0$. Finally, taking $F = D - D' > 0$ we get the result.

(\Leftarrow) Let $g_M(X) = \det(\text{Diag}(X) + M)$. By hypothesis $g_M(X)$ is an increasing function on $(\mathbb{R}_+ \cup \{0\})^n$ and therefore every first partial derivate is positive on $(\mathbb{R}_+ \cup \{0\})^n$. Also,

$$g_M(X) = \sum_{I \subseteq [n]} \det(M[I; I]) \cdot x_{I^c}, \text{ where } x_J = \prod_{j \in J} x_j \text{ for all } J \subseteq [n].$$

Now, we need to prove that $\det(M[J; J]) > 0$ for every $J \subsetneq [n]$. If $|J| = n - 1$, then $\det(M[J; J]) = \partial g / \partial x_j(0, \dots, 0) > 0$ for all $J = [n] \setminus j$ for some $j \in [n]$. Now, let $|J| < n - 1$, $y_i = x$ for $i \notin J$ and $y_i = 0$ for $i \in J$. If $\det(M[J; J]) < 0$ then the leading coefficient of $\partial f / \partial x(y_1, \dots, y_n)$ is negative, which is a contradiction since $\partial g / \partial x$ is positive on $(\mathbb{R}_+ \cup \{0\})^n$ and therefore $\det(M[J; J]) \geq 0$ for all $|J| < n - 1$. Now, there exists $i \in [n]$ such that $J \subsetneq [n] \setminus i = I$. Furthermore, $M[I; I]$ is an M -matrix (because is a Z -matrix and all its principal minors are non-negative), but given that $\det(M[I; I]) > 0$, $M[I; I]$ is actually a non-singular M -matrix. Therefore all the principal minors of $M[I; I]$ are positive and in particular, $\det(M[J; J]) > 0$. \square

Remark 3.2.5. Hence, given a non-negative matrix L of size n with zeros on the diagonal and $\mathbf{d} \in \mathbb{N}_+^n$ such that $L_d = \text{Diag}(\mathbf{d}) - L$ is a quasi non-singular M -matrix there exists a vector $\mathbf{d}' \in \mathbb{N}_+^n$ such that $\det(\text{Diag}(\mathbf{d} + \mathbf{d}') - L) \geq 0$. That is, $(\text{Diag}(\mathbf{d} + \mathbf{d}') - L)$ is an almost non-singular M -matrix. This can be summarized as that every square Z -matrix with a non-negative diagonal "aspires" to become an almost non-singular M -matrix.

At the beginning of this section we study arithmetical structures on non-negative matrices. However, we can ask what happens for arithmetical structures on an integer square matrix with zero diagonal but possibly negative off-diagonal entries? In this scenario some things can change as we can see in the following example.

Example 3.2.6. Suppose we insist on defining arithmetical structures on a general integer matrix A as pairs of vectors with positive integer entries satisfying condition

$$(\text{Diag}(\mathbf{d}) - A)\mathbf{r}^t = 0^t \text{ and } \mathbf{r} \text{ is primitive.}$$

Let

$$L = \begin{pmatrix} 0 & 3 & -1 \\ 0 & 0 & 2 \\ 1 & 1 & 0 \end{pmatrix} = \underbrace{\begin{pmatrix} 0 & 3 & 0 \\ 0 & 0 & 2 \\ 1 & 1 & 0 \end{pmatrix}}_{L^+} + \underbrace{\begin{pmatrix} 0 & 0 & -1 \\ 0 & 0 & 0 \\ 0 & 0 & 0 \end{pmatrix}}_{L^-}$$

Since L^+ is irreducible, then it has a finite number of arithmetical structures. Moreover, it is not difficult to check that L also has a finite number of arithmetical structures, namely;

$$((1, 4, 1), (1, 1, 2)), ((1, 2, 3), (2, 1, 1)), ((1, 1, 7), (5, 2, 1)), ((3, 3, 1), (1, 2, 3)),$$

$((5, 1, 3), (1, 2, 1))$ and $((2, 2, 2), (1, 1, 1)) = (L\mathbf{1}, \mathbf{1})$, its canonical arithmetical structure. Note that for each of the d -arithmetical structures of L we have that the matrix $L_d = \text{Diag}(\mathbf{d}) - L$ has positive proper principal minors and determinant equal to zero. In this sense the equivalence between the properties of the principal minors of L_d and the arithmetical structures of L established in Theorem 3.1.5 holds. Nevertheless, L is not a non-negative matrix and this example may be misleading as we will see next.

Now, let

$$K_a = \begin{pmatrix} 0 & 3 & 0 \\ 0 & 0 & 2 \\ -a & 1 & 0 \end{pmatrix} = \underbrace{\begin{pmatrix} 0 & 3 & 0 \\ 0 & 0 & 2 \\ 0 & 1 & 0 \end{pmatrix}}_{K^+} + \underbrace{\begin{pmatrix} 0 & 0 & 0 \\ 0 & 0 & 0 \\ -a & 0 & 0 \end{pmatrix}}_{K^-},$$

for some positive integer a . Note that K^+ is reducible and therefore has an infinite number of arithmetical structures. However, we have that K_a has only one arithmetical structure: $((6a, 1, 1), (1, 2a, a))$. In contrast with L , when the matrix has not all the entries of $K_a\mathbf{1}$ non-positive, we do not longer have the concept of a canonical arithmetical structure (at least not as we knew it). Moreover, note that the proper minor $(\text{Diag}(6a, 1, 1) - K_a)[\{2, 3\}]$ is equal to -1 for every a . Hence, in this infinite family of examples we have lost the essence of Theorem 3.1.5 and remark 3.2.5.

On the other hand, we may define the arithmetical structures of a general integer matrix with zero diagonal L in terms of the principal minors of L_d . See Section 4.2 for more information regarding this definition. Either way, the first challenge we encounter in this scenario is to establish a finiteness condition for the set of arithmetical structures.

3.3. The algorithm

This section contains the main results of this chapter, an algorithm that computes all the arithmetical structures on a non-negative matrix with zero diagonal. Before presenting the algorithm let us fix some notation. Let $\mathbf{d} \in \mathbb{N}_+^n$, $X = (x_1, x_2, \dots, x_n)$ and

$$f_{L,\mathbf{d}}(X) = \det(\text{Diag}(X + \mathbf{d}) - L).$$

For simplicity we write $f_L(X)$ instead of $f_{L,\mathbf{0}}(X)$. Now, let $\text{coef}_{L,\mathbf{d}}(x^a)$ be the coefficient of the monomial $\mathbf{x}^a = x_1^{a_1} \cdots x_n^{a_n}$ in $f_{L,\mathbf{d}}(X)$. The independent term of $f_{L,\mathbf{d}}(X)$ is equal to $\text{coef}_{L,\mathbf{d}}(\mathbf{x}^{\mathbf{0}}) = f_{L,\mathbf{d}}(\mathbf{0})$, which will be denoted by $c_{L,\mathbf{d}}$. The coefficients of $f_{L,\mathbf{d}}(X)$ that are not the independent term are called *proper coefficients*. Note that the coefficients of the polynomial $f_{L,\mathbf{d}}(X)$ are in correspondence with the principal minors of $(\text{Diag}(\mathbf{d}) - L)$. Thus, by inspecting the polynomial $f_{L,\mathbf{d}}(X)$ we can infer what type of (quasi) M -matrix $(\text{Diag}(\mathbf{d}) - L)$ is. In a similar manner, \mathbf{d} is a d -arithmetical structure of L if and only if $c_{L,\mathbf{d}} = 0$ and the proper coefficients of $f_{L,\mathbf{d}}(X)$ are positive. Next we will show a simple example for when the condition $c_{L,\mathbf{d}} = 0$ is not enough to guarantee that a vector is a d -arithmetical structure.

Example 3.3.1. Let P_5 be the path with five vertices,

$$\mathbf{r} = \begin{pmatrix} 1 \\ 1 \\ 0 \\ -1 \\ -1 \end{pmatrix} \text{ and } L_a = \begin{pmatrix} 1 & -1 & 0 & 0 & 0 \\ -1 & 1 & -1 & 0 & 0 \\ 0 & -1 & a & -1 & 0 \\ 0 & 0 & -1 & 1 & -1 \\ 0 & 0 & 0 & -1 & 1 \end{pmatrix} = \text{Diag}(1, 1, a, 1, 1) - A(P_5).$$

Since $L_a \mathbf{r} = \mathbf{0}$, then $\det(L_a) = 0$ for all $a \in \mathbb{N}_+$ and therefore

$$\mathcal{D}(L) \subsetneq \{\mathbf{d} \mid f_{L,\mathbf{d}}(0) = c_{L,\mathbf{d}} = 0\}.$$

Recall that $\mathcal{D}_{\geq 0}(L)$ was defined as the set of $\mathbf{d} \in \mathbb{N}_+^n$ such that $\text{Diag}(\mathbf{d}) - L$ is an almost non-singular M -matrix. Equivalently $\mathcal{D}_{\geq 0}(L)$ is the set of vectors $\mathbf{d} \in \mathbb{N}_+^n$ such that all nonconstant coefficients of $f_{L,\mathbf{d}}(X)$ are positive and $c_{L,\mathbf{d}} \geq 0$. Thus, by 3.2.4 the problem of getting an almost non-singular M -matrix from a quasi non-singular M -matrix by adding a positive vector to the diagonal is similar to the knapsack problem, see for instance [64] for an extensive study of the knapsack problem.

If M is a quasi non-singular M -matrix, let

$$\mathcal{C}(M) = \{\mathbf{d} \in \mathbb{N}_+^n \mid (M + \text{Diag}(\mathbf{d})) \text{ is an almost non-singular } M\text{-matrix}\}.$$

It is not difficult to check that $\mathcal{C}(M)$ exists and is finite by Dickson's Lemma. Now let $\min \mathcal{D}_{\geq 0}(L)$ be the set of all minimal elements of $\mathcal{D}_{\geq 0}(L)$, L_s is the submatrix of L that results from removing the s -th row and column. , for any $\mathbf{d} \in \mathbb{Z}^{n-1}$ and $1 \leq s \leq n$, let $\mathbf{d}^{(s)} \in \mathbb{Z}^n$ be given by

$$(\mathbf{d}^{(s)})_i = \begin{cases} \mathbf{d}_i & \text{if } 1 \leq i < s, \\ 1 & \text{if } i = s, \\ \mathbf{d}_{i-1} & \text{if } s < i \leq n. \end{cases} \quad (3.1)$$

Before presenting our first algorithm let us address the smaller case in the following result.

Lemma 3.3.2. If $a, b \in \mathbb{N}$, then

$$\min \mathcal{D}_{\geq 0} \begin{pmatrix} 0 & a \\ b & 0 \end{pmatrix} = \min \left\{ \left(\mathbf{d}, \max \left(1, \left\lceil \frac{ab}{\mathbf{d}} \right\rceil \right) \right) \mid \mathbf{d} \in \mathbb{N}_+, \mathbf{d} \leq \max(1, ab) \right\}, \quad (3.2)$$

Proof. This result is straightforward. Given a vector $(d_1, d_2) \in \mathbb{N}_+^2$, the only condition needed so that $(d_1, d_2) \in \min\mathcal{D}_{\geq 0} \begin{pmatrix} 0 & a \\ b & 0 \end{pmatrix}$, is that $d_1 d_2 \geq ab$. \square

Note that this is indeed the base case of the algorithm that follows next.

Algorithm 3.3.3.

Input: A non-negative square matrix L of size n with zero diagonal.

Output: $\min\mathcal{D}_{\geq 0}(L)$.

1. Compute $\tilde{A}_s = \min\mathcal{D}_{\geq 0}(L_s)$ for all $1 \leq s \leq n$.
 2. Let $A_s = \{\tilde{\mathbf{d}}^{(s)} \mid \tilde{\mathbf{d}} \in \tilde{A}_s\}$.
 3. **For** $\boldsymbol{\delta}$ in $\prod_{s \in [n]} A_s$:
 4. $\mathbf{d} = \sup \{\boldsymbol{\delta}_1, \dots, \boldsymbol{\delta}_n\}$.
 5. Let $S = \{s \mid \text{coef}_{L, \mathbf{d}}(x_s) = 0\}$ and $k = |S|$.
 6. *Find* (L, \mathbf{d}, k) :
 7. **While** $k > 0$:
 8. **If** $k=1$:
 9. Make $\mathbf{d}_s = \mathbf{d}_s + 1$ and *Find* $(L, \mathbf{d}, 0)$ for each $s \in S$.
 10. **Else**:
 11. Make $\mathbf{d}_s = \mathbf{d}_s + 1$ and *Find* $(L, \mathbf{d}, 0)$ for each $s \in S$.
 12. Make $\mathbf{d}_s = \mathbf{d}_s + 1$ and *Find* $(L, \mathbf{d}, 1)$ for each $s \notin S$.
 13. **For** $\mathbf{d}' \in \min\mathcal{C}(\text{Diag}(\mathbf{d}) - L)$:
 14. "Add" $\mathbf{d}' + \mathbf{d}$ to $\min\mathcal{D}_{\geq 0}(L)$.
 15. Return $\min\mathcal{D}_{\geq 0}(L)$.
-

The vector at step (4) is the (unique) minimal vector greater or equal than $\boldsymbol{\delta}_i$ for every $i \in [n]$. At step (6) we find all minimal vectors greater than \mathbf{d} such that all coefficients of $f_{L, \mathbf{d}}(X)$ are positive except, maybe, for the constant term. The function "add" at step (14) means that we add the vector $\mathbf{d}' + \mathbf{d}$ to the set $\min\mathcal{D}_{\geq 0}(L)$ whenever it is not greater than other vector already in the set. Afterwards, by erasing every vector greater than $\mathbf{d}' + \mathbf{d}$ from the set, the minimality of the set is assured.

Now, we are ready to prove the correctness of the Algorithm 3.3.3.

Theorem 3.3.4. *Algorithm 3.3.3 computes the set $\min\mathcal{D}_{\geq 0}(L)$ for any given non-negative matrix L with zero diagonal.*

Proof. We proceed by induction on the size of L . First, the case when L is a matrix of size 2 is solved by (3.2). Now, assume that the algorithm is correct for every matrix of size $1 \leq m \leq n-1$ and let L be a non-negative matrix with zero diagonal of size n . If \mathbf{d}' is a vector as given at step (4), then by Theorem 3.2.4 every vector $\mathbf{d} \geq \mathbf{d}'$ such that $(\text{Diag}(\mathbf{d}) - L)$ is an almost non-singular M -matrix is reached or found on steps (5) to (14). Therefore we only need to prove that every $\mathbf{d} \in \min\mathcal{D}_{\geq 0}(L)$ is reachable from some vector of the form presented at step (4).

Indeed, for every $\mathbf{d} \in \mathcal{D}_{\geq 0}(L)$, let $\mathbf{d}_{|s}$ be the vector equal to \mathbf{d} without the s -th entry. That is,

$$(\mathbf{d}_{|s})_i = \begin{cases} \mathbf{d}_i, & \text{if } 1 \leq i \leq s-1, \\ \mathbf{d}_{i+1}, & \text{if } s \leq i \leq n-1. \end{cases}$$

Then for every $s \in [n]$ $\mathbf{d}_{|s} \in \mathcal{D}_{\geq 0}(L_s)$ and there exists $\tilde{\mathbf{d}} \in \min\mathcal{D}_{\geq 0}(L_s)$ such that $\tilde{\mathbf{d}} \leq \mathbf{d}_{|s}$. Consequently, we have that $\mathbf{d}^{(s)}$ is as in (3.1), which concludes the proof. \square

Note that Algorithm 3.3.3 is not fast (not of polynomial-time), because the extended knapsack problem of finding $\mathcal{C}(M)$ is not in general of polynomial-time. On the other hand, thanks to the recursive structure of the algorithm, we get rid of the need of checking the value of the $2^n - 2$ proper principal minors of L . Now, we present the following algorithm that uses Algorithm 3.3.3.

Algorithm 3.3.5.

Input: A non-negative square matrix L with zero diagonal.

Output: $\mathcal{D}(L)$.

1. **If** (L is irreducible):
2. $A = \min\mathcal{D}_{\geq 0}(L)$,
3. $D = \{\mathbf{d} \in A : f_{L,\mathbf{d}}(\mathbf{0}) = 0\}$,
4. Return D .
5. **Elif** (L has a row equal to $\mathbf{0}$):
6. Return \emptyset .
7. **Else:**
8. 'there is an infinite number of arithmetical structures', (see Theorem 3.1.2).

Note that if we have a d -arithmetical structure on a matrix L , then it is very simple to get the corresponding r -arithmetical structure. We only need to compute the kernel of $\text{Diag}(\mathbf{d}) - L$. Now, we are able to present the correctness of Algorithm 3.3.5.

Corollary 3.3.6. *Algorithm 3.3.5 computes the set of arithmetical structures on any non-negative square matrix L with diagonal zero.*

Proof. It follows directly from Proposition 3.1.1 and Theorems 3.1.2, 3.1.5 and 3.3.4. \square

The next example illustrates how Algorithm 3.3.3 works. Moreover, it will give us a glance of its complexity.

Example 3.3.7. *Consider the graph G given in Figure 3.1 and let L be its adjacency matrix.*

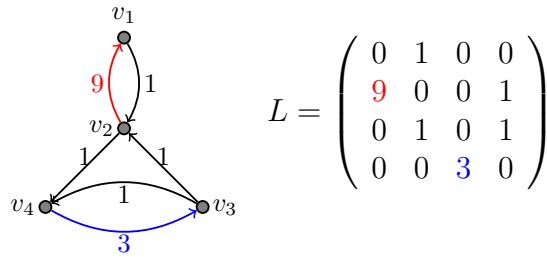

Figure 3.1: The digraph G and its adjacency matrix L .

Since G is a strongly connected graph, then L is an irreducible matrix. Therefore, the first step of Algorithm 3.3.5 consists of computing the sets $\min\mathcal{D}_{\geq 0}(L_s)$ for all the submatrices of L of size $n - 1$. It can be checked that $\min\mathcal{D}_{\geq 0}(L_1)$ is the set

$$\{(1, 2, 3), (1, 3, 2), (2, 1, 5), (2, 5, 1), (1, 1, 6), (1, 6, 1), (3, 1, 4), (3, 4, 1), (3, 2, 2)\},$$

$\min\mathcal{D}_{\geq 0}(L_2) = \{(1, 2, 2), (1, 1, 4), (1, 4, 1)\}$ and $\min\mathcal{D}_{\geq 0}(L_3) = \min\mathcal{D}_{\geq 0}(L_4)$
 $= \{(2, 5, 1), (5, 2, 1), (3, 4, 1), (4, 3, 1), (1, 10, 1), (10, 1, 1)\}$. From this we get that the set of vectors \mathbf{d} given at step (5) of Algorithm 3.3.3 is equal to

$$\left\{ \begin{array}{ccccc} (5, 2, 2, 3)_{-12}, & (5, 2, 3, 2)_{-12}, & (10, 1, 2, 3)_{-27}, & (10, 1, 3, 2)_{-27}, & (2, 5, 2, 2)_{-5}, \\ (3, 4, 2, 2)_{-6}, & (4, 3, 2, 2)_{-9}, & (1, 10, 2, 2)_{-2}, & (5, 2, 1, 5)_{-13}, & (5, 2, 5, 1)_{-13}, \\ (10, 1, 1, 6)_{-27}, & (10, 1, 6, 1)_{-27}, & (1, 10, 1, 4)_{-2}, & (1, 10, 4, 1)_{-2}, & (2, 5, 1, 4)_{-5}, \\ (2, 5, 4, 1)_{-2}, & (3, 4, 1, 4)_{-6}, & (3, 4, 4, 1)_{-6}, & (4, 3, 1, 4)_{-9}, & (4, 3, 4, 1)_{-9}. \end{array} \right\}$$

where the sub-index in each vector \mathbf{d} corresponds to the determinant of $(\text{Diag}(\mathbf{d}) - L)$. Following the rest of algorithm 3.3.3 we get that $\min\mathcal{D}_{\geq 0}(A(G))$ is equal to

$(5, 3, 2, 3)_3$	$(5, 3, 3, 2)_3$	$(9, 2, 2, 3)_0$	$(9, 2, 3, 2)_0$	$(6, 2, 3, 3)_0$
$(6, 2, 2, 5)_3$	$(6, 2, 5, 2)_3$	$(5, 2, 6, 3)_0$	$(5, 2, 3, 6)_0$	$(5, 2, 2, 9)_0$
$(5, 2, 9, 2)_0$	$(5, 2, 5, 4)_2$	$(5, 2, 4, 5)_2$	$(7, 2, 2, 4)_4$	$(7, 2, 4, 2)_4$
$(5, 5, 2, 2)_1$	$(2, 8, 2, 2)_1$	$(2, 5, 5, 2)_1$	$(2, 5, 2, 5)_1$	$(3, 6, 2, 2)_0$
$(2, 6, 3, 2)_3$	$(2, 6, 2, 3)_3$	$(2, 5, 3, 3)_0$	$(3, 4, 2, 3)_0$	$(3, 4, 3, 2)_0$
$(9, 4, 2, 2)_0$	$(1, 10, 3, 2)_0$	$(1, 10, 2, 3)_0$	$(1, 12, 2, 2)_0$	$(18, 1, 3, 3)_0$
$(10, 1, 11, 3)_0$	$(10, 1, 3, 11)_0$	$(14, 1, 4, 3)_3$	$(14, 1, 3, 4)_3$	$(12, 1, 5, 3)_0$
$(12, 1, 3, 5)_0$	$(12, 1, 4, 4)_3$	$(11, 1, 7, 3)_3$	$(11, 1, 3, 7)_3$	$(11, 1, 5, 4)_1$
$(11, 1, 4, 5)_1$	$(10, 1, 9, 4)_3$	$(10, 1, 4, 9)_3$	$(10, 1, 7, 5)_2$	$(10, 1, 5, 7)_2$
$(10, 1, 6, 6)_3$	$(23, 1, 2, 4)_1$	$(23, 1, 4, 2)_1$	$(16, 1, 2, 5)_1$	$(16, 1, 5, 2)_1$
$(14, 1, 2, 6)_3$	$(14, 1, 6, 2)_3$	$(12, 1, 2, 8)_3$	$(12, 1, 8, 2)_3$	$(11, 1, 2, 10)_1$
$(11, 1, 10, 2)_1$	$(10, 1, 2, 17)_1$	$(10, 1, 17, 2)_1$	$(4, 3, 4, 2)_3$	$(4, 3, 2, 4)_3$
$(4, 3, 3, 3)_6$	$(18, 2, 1, 5)_0$	$(18, 2, 5, 1)_0$	$(5, 2, 1, 18)_0$	$(5, 2, 18, 1)_0$
$(6, 3, 1, 5)_0$	$(6, 3, 5, 1)_0$	$(6, 2, 1, 9)_0$	$(6, 2, 9, 1)_0$	$(7, 2, 1, 8)_4$
$(7, 2, 8, 1)_4$	$(8, 2, 1, 7)_4$	$(8, 2, 7, 1)_4$	$(5, 3, 1, 6)_3$	$(5, 3, 6, 1)_3$
$(9, 2, 1, 6)_0$	$(9, 2, 6, 1)_0$	$(4, 4, 1, 5)_2$	$(4, 4, 5, 1)_2$	$(10, 2, 1, 6)_3$
$(10, 2, 6, 1)_3$	$(10, 1, 1, 33)_0$	$(10, 1, 33, 1)_0$	$(11, 1, 1, 20)_1$	$(11, 1, 20, 1)_1$
$(12, 1, 1, 15)_0$	$(12, 1, 15, 1)_0$	$(13, 1, 1, 13)_1$	$(13, 1, 13, 1)_1$	$(14, 1, 1, 12)_3$
$(14, 1, 12, 1)_3$	$(15, 1, 1, 11)_3$	$(15, 1, 11, 1)_3$	$(16, 1, 1, 10)_1$	$(16, 1, 10, 1)_1$
$(18, 1, 1, 9)_0$	$(18, 1, 9, 1)_0$	$(23, 1, 1, 8)_1$	$(23, 1, 8, 1)_1$	$(36, 1, 1, 7)_0$
$(36, 1, 7, 1)_0$	$(1, 12, 1, 4)_0$	$(1, 12, 4, 1)_0$	$(1, 11, 1, 5)_1$	$(1, 11, 5, 1)_1$
$(1, 10, 1, 6)_0$	$(1, 10, 6, 1)_0$	$(5, 5, 1, 4)_1$	$(5, 5, 4, 1)_1$	$(3, 6, 1, 4)_0$
$(3, 6, 4, 1)_0$	$(3, 5, 1, 5)_5$	$(3, 5, 5, 1)_5$	$(2, 8, 1, 4)_1$	$(2, 8, 4, 1)_1$
$(2, 6, 1, 5)_0$	$(2, 6, 5, 1)_0$	$(2, 5, 1, 9)_0$	$(2, 5, 9, 1)_0$	$(9, 4, 1, 4)_0$
$(9, 4, 4, 1)_0$	$(3, 4, 1, 6)_0$	$(3, 4, 6, 1)_0$	$(4, 3, 1, 7)_0$	$(4, 3, 7, 1)_0$

Thus, $\min \mathcal{D}_{\geq 0}(L)$ has 125 elements and 54 of them are d -arithmetical structures on L . The set $\mathcal{D}(L)$ is listed below.

$(9, 2, 2, 3)$	$(9, 2, 3, 2)$	$(6, 2, 3, 3)$	$(5, 2, 6, 3)$	$(5, 2, 3, 6)$
$(5, 2, 2, 9)$	$(5, 2, 9, 2)$	$(3, 6, 2, 2)$	$(2, 5, 3, 3)$	$(3, 4, 2, 3)$
$(3, 4, 3, 2)$	$(9, 4, 2, 2)$	$(1, 10, 3, 2)$	$(1, 10, 2, 3)$	$(1, 12, 2, 2)$
$(18, 1, 3, 3)$	$(10, 1, 11, 3)$	$(10, 1, 3, 11)$	$(12, 1, 5, 3)$	$(12, 1, 3, 5)$
$(18, 2, 1, 5)$	$(18, 2, 5, 1)$	$(5, 2, 1, 18)$	$(5, 2, 18, 1)$	$(6, 3, 1, 5)$
$(6, 3, 5, 1)$	$(6, 2, 1, 9)$	$(6, 2, 9, 1)$	$(9, 2, 1, 6)$	$(9, 2, 6, 1)$
$(10, 1, 1, 33)$	$(10, 1, 33, 1)$	$(12, 1, 1, 15)$	$(12, 1, 15, 1)$	$(18, 1, 1, 9)$
$(18, 1, 9, 1)$	$(36, 1, 1, 7)$	$(36, 1, 7, 1)$	$(1, 12, 1, 4)$	$(1, 12, 4, 1)$
$(1, 10, 1, 6)$	$(1, 10, 6, 1)$	$(3, 6, 1, 4)$	$(3, 6, 4, 1)$	$(2, 6, 1, 5)$
$(2, 6, 5, 1)$	$(2, 5, 1, 9)$	$(2, 5, 9, 1)$	$(9, 4, 1, 4)$	$(9, 4, 4, 1)$
$(3, 4, 1, 6)$	$(3, 4, 6, 1)$	$(4, 3, 1, 7)$	$(4, 3, 7, 1)$	

We finish this section by presenting computational data about arithmetical structures of graphs with less or equal to five vertices. Additionally, this data provides evidence for conjecture 3.3.8.

Conjecture 3.3.8. [42, Conjecture 6.10] *If G is a simple graph with n vertices, then*

$$\left| \mathcal{A}(P_n) \right| \leq \left| \mathcal{A}(G) \right| \leq \left| \mathcal{A}(K_n) \right|,$$

where P_n and K_n are the path with and the complete graph with n vertices respectively.

In simple words, conjecture 3.3.8 says that for graphs, arithmetical structures are most simple when it is a path and the most complicated case happens when it is the complete graph. Moreover, when G is the star graph with n leaves, then its arithmetical structures satisfy that $\sum_{i=1}^n \frac{1}{d_i} \in \mathbb{N}_+$. Thus the arithmetical structures on the star with $n+1$ vertices are more complicated than the arithmetical structures on the complete graph with n vertices. In general, for many graphs with $n+1$ vertices, their arithmetical structures are at least as complicated as the arithmetical structures on K_n .

There exists upper bounds for the entries of vector \mathbf{r} of an arithmetical structure. For instance, when G is a graph with n vertices and $e(G)$ its number of edges, [65, Theorem 3.4] establish that

$$\mathbf{r} \leq \frac{1}{(n-1)!} e(G)^{3 \cdot 2^{n-2} - 2} \mathbf{1}.$$

This upper bound will lead to a brute force algorithm with time complexity of the order of

$$\frac{n^2}{((n-1)!)^n} e(G)^{n(3 \cdot 2^{n-2} - 2)} \geq n^2 (n-1)^{3n \cdot 2^{n-2} - 2n - n^2} \text{ for any connected graph } G$$

Moreover, this brute-force algorithm applied to the complete graph K_n would have a complexity of the order of

$$n^{3n \cdot 2^{n-2} - 2n + 2} \cdot \frac{(n-1)^{n(3 \cdot 2^{n-2} - 2)}}{((n-1)!)^n}.$$

A deeper study of the possible value of the largest entry of an arithmetical structure on the complete graph is conducted in [58]. Let us recall that the d -arithmetical structures of the complete graph are directly related to the Egyptian fractions of 1. In order to have an idea of the complexity of arithmetical structures on the complete graph see the sequence A002967 [60]. It shows that

$$\left| \mathcal{A}(K_6) \right| = 2025462, \left| \mathcal{A}(K_7) \right| = 1351857641 \text{ and } \left| \mathcal{A}(K_8) \right| \simeq 6.25 \times 10^{12}.$$

On the other hand, the largest d_i such that $\mathbf{d} \in \mathcal{D}(K_n)$ is given by the Sylvester's sequence $a(n) = a(n-1)(a(n-1) - 1) + 1$ with $a(0) = 2$. For instance the highest d_i in a d -arithmetical structure of K_8 is about 1.13×10^{26} . Equivalently $\max\{d_i \mid i = 1, \dots, n\} = \lfloor C^{2^n} + \frac{1}{2} \rfloor$, where $C \simeq 1.2640847353$ is the Vardi constant. Thus a brute force algorithm based on this upper bound for the entries of the d -arithmetical structure of the complete graph is of the order of $n^6 C^{n \cdot 2^n}$.

The reader can find a code for Algorithm 3.3.3, written in sagemath [85], at the link in [91]. Note that the implementation of the algorithm can be improved. For instance, in the code given above we are using only the minimal elements in the set defined by steps (3) and (4). For the case of simple graphs, we can further improve the computation using the symmetry of the graph. More precisely, the twin vertices of the graph. Let G be a graph, a pair of vertices $w, v \in V(G)$ are said to be twins if $N_G(w) \setminus \{v\} = N_G(v) \setminus \{w\}$. Now, assume G is a simple graph and $w, v \in V(G)$ are twins. If \mathbf{f} is a d -arithmetical structure of $G - w$. Then, for $G - v$, there is a d -arithmetical structure \mathbf{h} , such that $\mathbf{h}_u = \mathbf{f}_u$ for every $w \neq u \neq v$ and $\mathbf{h}_w = \mathbf{f}_v$. Hence, we can relax step (3) of Algorithm 3.3.3 by removing the two sets corresponding to a pair of twin vertices and adding instead a similar set of the same size. A similar observation can be made for larger sets of twin vertices. A code for simple graphs of five vertices implementing this changes can also be found in [91]. Moreover, we can proceed similarly for multidigraphs if all the weights of all the corresponding edges of the twin vertices in question are equal. In Table 3.1 we list all connected graphs with three and four vertices together with the number of arithmetical graphs and the number of elements in $\min\mathcal{D}_{\geq 0}(A(G))$. As well as for the seven graphs on 5 vertices with fewer elements in $\min\mathcal{D}_{\geq 0}(L)$, which are also the fastest to compute. Similarly for Tables 3.2 and 3.3, therein we also present the total execution time for each graph and the average execution time for each element found by Algorithm 3.3.3 (amortized execution time).

The time complexity of Algorithm 3.3.3 is difficult to approximate in general. For simple graphs, the time complexity is of the order of

$$(n^k) \prod_{s \in [n]} |\min\mathcal{D}_{\geq 0}(L_s)| \max_{\mathbf{d} \in \min\mathcal{D}_{\geq 0}(L)} \left(\prod_{i \in [n]} d_i \right),$$

for some constant $k > 0$. Note that for the complete graph with n vertices, applying the twin vertices method describe above. Then the time complexity is of the order

$$(n^k) |\min\mathcal{D}_{\geq 0}(A(K_{n-1}))| C^{2^{(2^n-1)}}.$$

Improving the execution time for K_n by a factor of order $|\min\mathcal{D}_{\geq 0}(A(K_{n-1}))|^{n-1}$. This means that, for instance, instead of roughly 13.5 hours of execution time for K_5 , as seen in Table 3.3. The same computer would take several months to finish computing Algorithm 3.3.3 without using the symmetries of twin vertices.











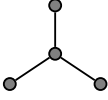
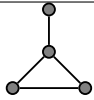

Graph	$ \mathcal{A} $	$ \min\mathcal{D}_{\geq 0} $	Graph	$ \mathcal{A} $	$ \min\mathcal{D}_{\geq 0} $
	2	2		10	10
	5	5		14	14
	26	42		35	35
	63	137		215	323
	14	14		46	62
	126	126		102	162
	134	245		120	300
	263	371			

Table 3.1: This table presents some small graphs together with their number of arithmetical structures ($|\mathcal{A}|$) and the size of the output of Algorithm 3.3.3 ($|\min\mathcal{D}_{\geq 0}|$).

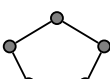

Graph	$ \mathcal{A} $	$ \min \mathcal{D}_{\geq 0} $	Total exec. Time	Amortized exec. Time
	257	809	29.7 sec.	36.7 ms.
	388	845	27.5 sec.	32.5 ms.
	290	864	30.3 sec.	35.0 ms.
	571	960	7.6 sec.	7.9 ms.
	835	1531	121.3 sec.	79.2 ms.
	449	1771	181.0 sec.	102.2 ms.
	987	2524	115.3 sec.	45.7 ms.
	1079	3311	530.6 sec.	160.2 ms.

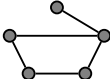
Table 3.2: In this table we also list the total and amortized execution times for these eight graphs on five vertices, presented in seconds and milliseconds respectively.

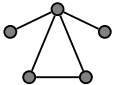
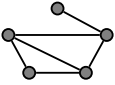
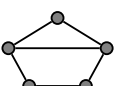

Graph	$ \mathcal{A} $	$ \min \mathcal{D}_{\geq 0} $	Total exec. Time	Amortized exec. Time
	489	3647	51.6 min.	0.84 sec.
	2181	4942	32.3 min.	0.39 sec.
	1419	7405	34.3 min.	0.28 sec.
	1541	8702	74.1 min.	0.51 sec.
	3325	17349	228.8 min.	0.79 sec.
	12231	32701	797.6 min.	1.46 sec.

Table 3.3: This table presents the last six connected graphs on five vertices. Note that the total execution time is presented in minutes and the amortized time is presented in seconds.

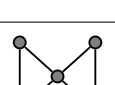
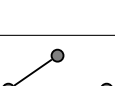
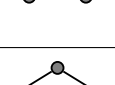
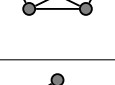
Arithmetical Structures of Dominated Polynomials

In this chapter we explore the concept of arithmetical structures for some polynomials which are not described by the determinant of some matrix with indeterminate diagonal entries but preserve certain properties. In particular, we study this concept for *dominated polynomials*. All this leads to an algorithm that computes arithmetical structures of dominated polynomials.

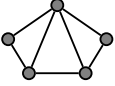
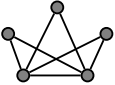
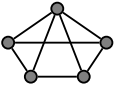
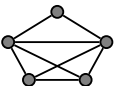
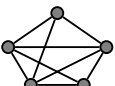
We introduce the concept of arithmetical structures for a general integer square-free dominated polynomial and study some of its algorithmic aspects. More precisely, we give an algorithm that computes some minimal elements for this wider class of polynomials. We give an example of a polynomial that is not the determinant of an integer matrix and show how the algorithm works for it. Lastly we explore the limits of the algorithm with several examples.

In section 4.1, we provide the motivation of this chapter and establish the relationship between this algorithm and Hilbert's tenth problem. Note that if (\mathbf{d}, \mathbf{r}) is an arithmetical structure of A , then \mathbf{d} is a solution of the Diophantine equation

$$f_L(X) = \det(\text{Diag}(X) - L) = 0. \quad (4.1)$$

However, the converse is false. Meaning that not every solution is part of an arithmetical structure. The smaller simple graph where we can find such solution is the path with five vertices. Nevertheless the algorithm provides a way of finding these different positive solutions. Therefore we may say that Hilbert's tenth problem is solved for polynomials of this form. Moreover, it is known that there are methods such that by finding all positive solutions to a Diophantine equation we can know all of the integer solutions [45].

In section 4.2 we generalize the concept of (d -)arithmetical structure for a class of polynomials we call dominated polynomials. A polynomial is dominated if every non-leading monomial is a factor of the leading monomial. We claim that this property is the main one that characterizes the behaviour of the determinantal equation 4.1. It is important to note that there are dominated polynomials that are not represented by the determinant of an integer matrix, in contrast to equation 4.1.

In section 4.3 we generalize the ideas developed to solve the problem over matrices are generalized to the class dominated polynomials. Leading to an Algorithm (3.3.3) that computes the arithmetical structures of dominated polynomials.

In section 4.4 we will approach Hilbert's tenth problem for the dominated polynomials. With respect to this, we will explore the limitations of the algorithm with several examples.

4.1. Motivation

At this point, given an integer matrix L with diagonal zero we have an algorithm that computes all of its arithmetical structures. Thus, it is natural to ask: When a polynomial is the determinant of a matrix with diagonal X ? In the following we will see that not every polynomial is the determinant of a matrix of the form

$$\text{Diag}(X) - L.$$

Moreover, we show that the set of monic (every term) square-free polynomials that are the determinant of a matrix $\text{Diag}(X) - L$ is in some sense very small. Firstly, it is clear that if a polynomial is equal to $\det(\text{Diag}(X) - L)$, then it must be monic (the coefficient of the monomial $x_1x_2 \dots x_n$ is always 1) and (every term) square-free. Therefore we restrict to monic polynomials with every term square-free. For the rest of this chapter we will simply call them monic and square-free polynomials, unless otherwise stated. Let $\mathbb{Z}[X]^*$ be

$$\{f \in \mathbb{Z}[X] \mid f \text{ is monic and square-free}\}/(\sim),$$

where $f \sim g$ if there exists $\mathbf{d} \in \mathbb{Z}^n$ such that $f(X + \mathbf{d}) = g(X)$. We consider two polynomials equivalent when one can be obtained as an evaluation of the other because their integer solutions are essentially the same. Note that $\mathbb{Z}[X]^*$ is isomorphic to

$$\{f \in \mathbb{Z}[X] \mid f \text{ is monic square-free with } \text{coef}\left(\frac{\prod_{i=1}^n x_i}{x_j}\right) = 0 \text{ for all } 1 \leq j \leq n\}.$$

Also, let

$$\text{MIP}[X] = \{f \in \mathbb{Z}[X]^* \mid f = \det(\text{Diag}(X) - L) \text{ for some matrix } L \text{ with zero diagonal}\}.$$

Clearly

$$\text{MIP}[X] \subseteq \mathbb{Z}[X]^*.$$

If $|X| = 2$, we can easily check that equality holds, that is, $\text{MIP}[x_1, x_2] = \mathbb{Z}[x_1, x_2]^*$. In a similar way, for $|X| = 3$ we will prove the following result.

Proposition 4.1.1. *If $X = (x_1, x_2, x_3)$, then*

$$\text{MIP}[X] = \{f = x_1x_2x_3 + a_1x_1 + a_2x_2 + a_3x_3 + b \in \mathbb{Z}[X]^* \mid b = \frac{a_1a_2a_3 - n^2}{n} \in \mathbb{Z}\}.$$

Proof. Let

$$A = \begin{pmatrix} 0 & a_{1,2} & a_{1,3} \\ a_{2,1} & 0 & a_{2,3} \\ a_{3,1} & a_{3,2} & 0 \end{pmatrix}$$

be an integer matrix with zero diagonal. Then the determinant of

$$(\text{Diag}(x_1, x_2, x_3) - A)$$

is equal to

$$x_1x_2x_3 - a_{2,3}a_{3,2}x_1 - a_{1,3}a_{3,1}x_2 - a_{1,2}a_{2,1}x_3 + (-a_{1,3}a_{2,1}a_{3,2} - a_{1,2}a_{2,3}a_{3,1})$$

Now, let us set

$$a_1 = -a_{2,3}a_{3,2}, \quad a_2 = -a_{1,3}a_{3,1}, \quad a_3 = -a_{2,3}a_{3,2} \quad \text{and} \quad b = (-a_{1,3}a_{2,1}a_{3,2} - a_{1,2}a_{2,3}a_{3,1}).$$

Therefore, $b = \frac{a_1a_2a_3}{a_{1,2}a_{2,3}a_{3,1}} - a_{1,2}a_{2,3}a_{3,1}$. We know that both b and $a_{1,2}a_{2,3}a_{3,1}$ are

integer numbers. Then $a_{1,2}a_{2,3}a_{3,1}$ is a divisor of $a_1a_2a_3$, since $\frac{a_1a_2a_3}{a_{1,2}a_{2,3}a_{3,1}}$ is also an

integer. Now, we can conclude that $b = \frac{a_1a_2a_3}{n} - n$, where n divides $a_1a_2a_3$. \square

Note that $b \in \mathbb{Z}$ if and only if n divides $a_1a_2a_3$. If $a_1a_2a_3 \neq 0$, then there is a finite set of b 's on \mathbb{Z} such that $f = x_1x_2x_3 + a_1x_1 + a_2x_2 + a_3x_3 + b$ is in $\text{MIP}[x_1, x_2, x_3]$ and therefore $\text{MIP}[X] \subsetneq \mathbb{Z}[X]^*$ for all $n \geq 3$. On the other hand, if $a_1a_2a_3 = 0$, then $x_1x_2x_3 + a_1x_1 + a_2x_2 + a_3x_3 + b$ is in $\text{MIP}[x_1, x_2, x_3]$ for every $b \in \mathbb{Z}$. Furthermore, if f comes from a matrix, then

$$f = \det \begin{bmatrix} x_1 & -n_3 & \frac{a_2}{n_2} \\ \frac{a_3}{n_3} & x_2 & -n_1 \\ -n_2 & \frac{a_1}{n_1} & x_3 \end{bmatrix},$$

where $n = n_1n_2n_3$ and $n_i|a_i$ (here we are considering every integer as a “divisor” of 0).

Next example will helpfull to illustrate this.

Example 4.1.2. *If $g = x_1x_2x_3 - 19x_1 + 2x_2 + 3x_3 + b$, then*

$$b = \frac{-114}{n} - n, \quad \text{where } n \in \text{Div}(114) = \pm\{1, 2, 3, 6, 19, 38, 57, 114\}.$$

Which implies that $b \in \pm\{25, 41, 59, 115\}$. It is not difficult to check by Proposition 4.1.1 that $f(x_1, x_2, x_3) = x_1x_2x_3 - 19x_1 + 2x_2 + 3x_3 - 23 \notin \text{MIP}[x_1, x_2, x_3]$.

When $n \geq 4$ we have similar restrictions for the coefficients of the polynomial f . Moreover, the gap between $\text{MIP}[X]$ and $\mathbb{Z}[X]^*$ grows as n grows.

Let R be a ring, then Hilbert's tenth problem for R (HTP(R)) is to determine if there is an algorithm such that it can classify any polynomial (with coefficients in

R) to whether have a solution in R or not. Based on important preliminary work by Martin Davis, Hilary Putnam and Julia Robinson, Yuri V. Matiyasevich showed in 1970 that $\text{HTP}(\mathbb{Z})$ has a negative answer. That is, that in general no such algorithm exists (see [74]). Since then, several authors have proposed different versions of HTP. Now, if \mathcal{F} is a set of polynomials with coefficients on R , we state the following problem:

Problem 4.1.3. *Determine if there exists an algorithm such that given any polynomial $p \in \mathcal{F}$, then it can answer if p has a solution in R or not.*

Let us call this the Hilbert's tenth problem for \mathcal{F} , denoted by $\text{HTP}(\mathcal{F}, R)$. Note that if \mathcal{F} consists of all polynomials with coefficients in R , then $\text{HTP}(\mathcal{F}, R)$ is equivalent to $\text{HTP}(R)$.

Before Matiyasevich's negative solution for \mathbb{Z} there were some efforts to build algorithms for some special families of polynomial Diophantine equations. We reclaimed that approach for a particular set of polynomials. That is, in this case HTP can be solved in a positive way ($\text{HTP}(\{\text{polynomials of the form } f_L(X)\}, \mathbb{Z})$).

Now, we could also ask:

Question 4.1.4. *What makes this type of Diophantine equation special in such a way that we can determine HTP?*

We answer by introducing the class of polynomials f that have a monomial m such that any other monomial of f is a factor of m . These are called dominated polynomials.

In Figure 4.1 we illustrate where this work is placed in the framework of HTP. Recall that any ring R such that $\mathbb{Z} \subsetneq R \subsetneq \mathbb{Q}$ is of the form $R = \mathbb{Z}[S^{-1}]$, where S is a subset of the prime numbers \mathcal{P} .

We mentioned previously that $\text{HTP}(\mathbb{Z})$ was solved (negatively) by Matiyasevich. In [83] it was proven that if S is finite, then $\text{HTP}(\mathbb{Z}[S^{-1}])$ has a negative answer. Moreover, $\text{HTP}(\mathbb{Z}[S^{-1}])$ has a negative answer for some infinite but co-infinite ($\mathcal{P} - S$ infinite) sets S , some examples are given in [82]. We refer the reader to [87] for different algorithmic approaches to HTP for several families of Diophantine equations. We solved HTP for \mathcal{D}_I (irreducible dominated polynomials) over \mathbb{Z} and give an algorithm that computes all arithmetical structures explicitly is given. On the other hand, $\text{HTP}(\mathbb{Q})$ is still open and if $\mathcal{P} - S$ is finite then $\text{HTP}(\mathbb{Z}[S^{-1}])$ is equivalent to $\text{HTP}(\mathbb{Q})$ by [83]. In [51] several examples are constructed with S both infinite and co-infinite and such that $\text{HTP}(\mathbb{Z}[S^{-1}])$ is equivalent to $\text{HTP}(\mathbb{Q})$. HTP for rings of integers of number fields remains open in general.

Inspired by Algorithms 3.3.3 and 3.3.5, at the following sections we generalize some of the ideas presented before (for the polynomials which are the determinant of a matrix with variables in the diagonal) to dominated polynomials. Some concepts are preserved in this new setting and others are not. For instance, the concept of d -arithmetical structure is generalized easily. However, we were not able to find a good definition for an r -arithmetical structure.

An algorithm similar to Algorithm 3.3.5 that computes the d -arithmetical structures for dominated polynomials is presented. This algorithm does not compute every

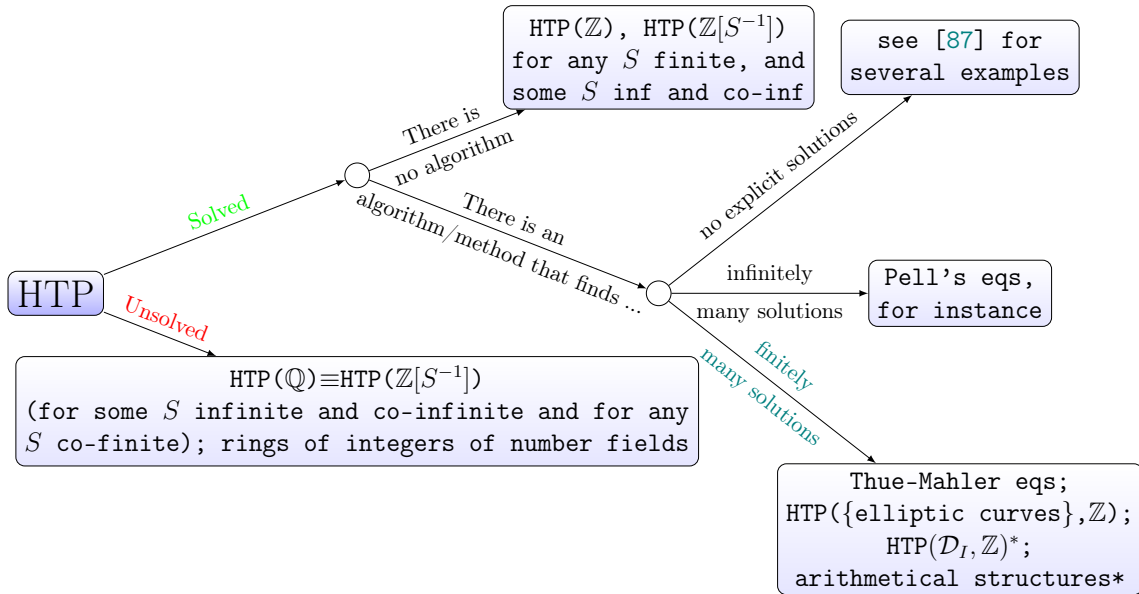

Figure 4.1: A concept map of the current state of Hilbert’s tenth problem and the relation with this work.

integer solutions of a dominated polynomial. However we can extend the algorithm to find other solutions. We show some examples of polynomials for which it is possible to obtain every positive integer solution by simple extensions of our algorithm. Also, we show an example of an irreducible dominated polynomial with infinite positive solutions which proves that this is not always possible.

4.2. Dominated polynomials

First, since the set of solutions of the product of two polynomials can be easily obtained in function of the solutions of each polynomial in this setting, then we can assume that the polynomial is irreducible. Moreover, by using some simple changes of variable (of the type $x_i = -x_i$) we can get all the integer solutions from the positive ones and therefore we can restrict to positive integer solutions only. From now on all the polynomials that we consider are dominated and square-free. We continue by introducing dominated polynomials.

Given a set of monomials \mathcal{F} in $\mathbb{Z}[x_1, x_2, \dots, x_n]$, a monomial $p \in \mathcal{F}$ is called a dominant monomial of \mathcal{F} whenever it is divided by every monomial in \mathcal{F} (any other monomial in \mathcal{F} is a factor of p). Is not difficult to check that if \mathcal{F} has a dominant monomial, then it is unique. Let \mathcal{F}_f be the set of monomials with non-zero coefficient on the polynomial f .

Definition 4.2.1. *A polynomial $f \in \mathbb{Z}[x_1, \dots, x_n]$ is dominated when \mathcal{F}_f has a dominant monomial.*

Let f be a dominated polynomial and $p_f \in \mathcal{F}_f$ be its dominant monomial. If p_f is square-free, then f is called a square-free dominated polynomial. Moreover, if f is

a polynomial such that every variable appears at least once, then f is a dominated square-free polynomial if and only if

$$\prod_{i=1}^n x_i \in \mathcal{F}_f,$$

which is precisely its dominant monomial. Let $f_{\mathbf{d}}(X)$ denote $f(X + \mathbf{d})$.

Now we can proceed to give a definition of a d -arithmetical structure of a polynomial.

Definition 4.2.2. *Let $f \in \mathbb{Z}[X]$ be an irreducible square-free dominated polynomial with its leading coefficient positive. An arithmetical structure of f is a vector $\mathbf{d} \in \mathbb{N}_+^n$ such that $f(\mathbf{d}) = 0$ and all the non-constant coefficients of $f_{\mathbf{d}}(X)$ are positive.*

If f does not have its leading coefficient positive, then it does not have any arithmetical structures. On the other hand, since either f or $-f$ has its leading coefficient positive, then we can assume that f has positive leading coefficient. From now on, let us assume that the leading coefficient is always positive unless the contrary is stated.

When the polynomial $f \in \mathbb{Z}[X]$ is not irreducible, that is $f = \prod_{i=1}^s f_i$ for some irreducible square-free polynomials f_i , we need to introduce some extra notation. Since f is square-free, the set of variables of the f_i 's does not intersect and therefore each f_i is a dominated polynomial. Thus, given $\mathbf{d} \in \mathbb{Z}^n$, let $\mathbf{d}(f_i)$ be the vector with the entries of \mathbf{d} that corresponds to the variables of f_i . In the general case of reducible square-free polynomials an arithmetical structure is a $\mathbf{d} \in \mathbb{Z}^n$ such that $\mathbf{d}(f_i)$ is an arithmetical structure of at least one of the f_i and the non-constant coefficients of $f_{i, \mathbf{d}(f_i)}(X)$ are positive and the constant coefficient is non-negative for all i . Thus when f is reducible square-free polynomial, then it has an infinite number of arithmetical structures.

Definition 4.2.3. *Given a square-free dominated polynomial f on n variables, let*

$$\mathcal{D}(f) = \{\mathbf{d} \in \mathbb{N}_+^n \mid \mathbf{d} \text{ is an arithmetical structure of } f\}.$$

It is not difficult to check that this definition generalizes the one given in Section 3.1. More precisely, $\mathcal{D}(L) = \mathcal{D}(f_L)$ for any non-negative matrix with zero diagonal L .

Defining an r -arithmetical structure of an integer square-free dominated polynomial is a more difficult task. First, note that the r -arithmetical structures of L and L^t are equal if and only if L is symmetric. However, $f_L(X) = f_{L^t}(X)$ for any $L \in M_n(\mathbb{Z})$ because the determinant of a matrix is invariant under the transpose, that is, $\det(L) = \det(L^t)$. Moreover, if M is a matrix without rows or columns equal to zero, then $\mathcal{D}(L) = \mathcal{D}(L^t)$. Hence the polynomial $f_L(X)$ does not distinguish between L and L^t . However r -arithmetical structures of L and L^t are not equal when L is not symmetric. Therefore in general we may not try to extract the information of the r -arithmetical structures from $f_L(X)$.

Example 4.2.4. If $M = \begin{pmatrix} 0 & 1 \\ 3 & 0 \end{pmatrix}$, then $f_L(x_1, x_2) = f_{L^t}(x_1, x_2) = x_1x_2 - 3$ and therefore

$$\mathcal{A}(L) = \{((1, 3), (1, 1)), ((3, 1), (1, 3))\} \text{ and } \mathcal{A}(L^t) = \{((1, 3), (3, 1)), ((3, 1), (1, 1))\}.$$

Thus $\mathcal{D}(f_L) = \{(1, 3), (3, 1)\} = \mathcal{D}(f_{L^t})$ and

$$\mathcal{R}(f_L) = \{(1, 1), (1, 3)\} \neq \{(1, 1), (3, 1)\} = \mathcal{R}(f_{L^t}).$$

Remark 4.2.5. If a polynomial f in $\text{MIP}[X]$ is irreducible, then it comes from an irreducible matrix.

Since a symmetric Z -matrix M is an almost non-singular M -matrix with $\det(M) = 0$ if and only if there exists $\mathbf{r} > 0$ such that

$$\text{Adj}(M) = |K(M)| \mathbf{r}^t \mathbf{r} > \mathbf{0},$$

where $\ker_{\mathbb{Q}}(M) = \langle \mathbf{r} \rangle$ and $K(M)$ is the sandpile group of M , see [42, Proposition 3.4]. Then is factible to define the sandpile group of a d -arithmetical structure of a polynomial f as

$$|K(f, \mathbf{d})| = \gcd(\text{coef}_{f_{\mathbf{d}}(X)}(x_1), \dots, \text{coef}_{f_{\mathbf{d}}(X)}(x_n)).$$

Given any non-negative matrix with zero diagonal L such that every of its rows are different from $\mathbf{0}$, then $(L\mathbf{1}, \mathbf{1})$ is the canonical arithmetical structure of L . In general for polynomials in $\mathbb{Z}[X]^*$ we cannot recover the concept of canonical arithmetical structure. Furthermore, some polynomials are extremal in the sense that they have very few arithmetical structures. We illustrate this idea at the next example.

Example 4.2.6. Returning to the polynomial of example 4.1.2,

$$f(x_1, x_2, x_3) = x_1x_2x_3 - 19x_1 + 2x_2 + 3x_3 - 23 \notin \text{MIP}[x_1, x_2, x_3].$$

By evaluating, it is easy to see that $(d_1, d_2, d_3)\mathbb{N}_+^3$ is an arithmetical structure of f if and only if

$$d_2d_3 - 19 \geq 1 \text{ and } (d_2d_3 - 19)d_1 + 2d_2 + 3d_3 = 23.$$

Thus we have that $\mathcal{D}(f) = \{(1, 5, 4)\}$. A follow up problem would be to study this type of polynomials, where we have a single d -arithmetical structure.

4.3. An algorithm for the polynomial case

In this section we extend Algorithms 3.3.3 and 3.3.5 to find arithmetical structures of a square-free dominated polynomial with integer coefficients. First, let

$$\mathcal{D}_{\geq 0}(f) = \left\{ \mathbf{d} \in \mathbb{N}_+^n \mid \text{all non-constant coefficients of } f_{\mathbf{d}}(X) \text{ positive and } f(\mathbf{d}) \geq 0 \right\}.$$

Now, we are ready to present our algorithm.

Algorithm 4.3.1.

Input: A square-free dominated polynomial f over \mathbb{Z} .

Output: $\min\mathcal{D}_{\geq 0}(f)$ and $\mathcal{D}(f)$.

1. **If** f is irreducible:
2. Let $\partial_s f = \frac{\partial f}{\partial x_s}$ for all $1 \leq s \leq n$.
3. Compute $\tilde{A}_s = \min\mathcal{D}_{\geq 0}(\partial_s f)$ for all $1 \leq s \leq n$.
4. Let $A_s = \{\tilde{\mathbf{d}}^{(s)} \mid \tilde{\mathbf{d}} \in \tilde{A}_s\}$.
5. **For** $\boldsymbol{\delta}$ in $\prod_{s \in [n]} A_s$:
6. $\mathbf{d} = \sup\{\boldsymbol{\delta}_1, \dots, \boldsymbol{\delta}_n\}$.
7. Let $S = \{s \mid \text{coef}_{\mathbf{d}}(x_s) = 0\}$ and $k = |S|$.
8. $\text{Find}(f, \mathbf{d}, k)$:
9. **While** $k > 0$:
10. **If** $k = 1$:
11. Make $\mathbf{d}_s = \mathbf{d}_s + 1$ and $\text{Find}(f, \mathbf{d}, 0)$ for each $s \in S$.
12. **Else:**
13. Make $\mathbf{d}_s = \mathbf{d}_s + 1$ and $\text{Find}(f, \mathbf{d}, 0)$ for each $s \in S$.
14. Make $\mathbf{d}_s = \mathbf{d}_s + 1$ and $\text{Find}(f, \mathbf{d}, 1)$ for each $s \notin S$.
15. **For** $\mathbf{d}' \in \min\mathcal{C}(f(\mathbf{X} + \mathbf{d}))$:
16. Add $\mathbf{d}' + \mathbf{d}$ to $\min\mathcal{D}_{\geq 0}(f)$.
17. Return $\min\mathcal{D}_{\geq 0}(f)$ and $\mathcal{D}(f) = \{\mathbf{d} \in \min\mathcal{D}_{\geq 0}(f) \mid f(\mathbf{d}) = 0\}$.
18. **Else:** (f is reducible)
19. Compute $A_s = \min\mathcal{D}_{\geq 0}(f_s)$ for all irreducible factors f_s of f .
20. "Choose all possible combinations".

Remark 4.3.2. Since f is square-free, its irreducible factors do not share variables. Therefore, step (20) refers to choose an element in $\mathcal{D}(f_i)$ for some irreducible factor f_i of f . Choose an element in $\mathcal{D}_{\geq 0}(f_j)$ for some $j \neq i$ and merging these vectors to get an arithmetical structure of f .

We are ready to prove the correctness of Algorithm 4.3.1. The prove will be similar to the one given for Algorithm 3.3.3. Thus we begin by extending Lemma 3.3.2 for the polynomial case.

Lemma 4.3.3. *If $a, b_1, b_2, c \in \mathbb{Z}$, $a \geq 1$ and $f = ax_1x_2 + b_1x_1 + b_2x_2 + c$, then the set $\min\mathcal{D}_{\geq 0}(f)$ is equal to*

$$\min \left\{ \left(d, \max \left(d_2^+, \left\lceil \frac{-(c + b_1d)}{ad + b_2} \right\rceil \right) \right) \mid d \in \mathbb{N}_+, d_1^+ \leq d \leq \max \left(d_1^+, \left\lceil \frac{-(c + b_2d_2^+)}{ad_2^+ + b_1} \right\rceil \right) \right\},$$

where $d_1^+ = \max(1, \lceil \frac{1-b_1}{a} \rceil)$ and $d_2^+ = \max(1, \lceil \frac{1-b_2}{a} \rceil)$.

Proof. A vector $\mathbf{d} = (d_1, d_2) \in \mathbb{Z}^2$ is in $\mathcal{D}_{\geq 0}(f)$ if and only if

$$d_1 \geq 1, ad_1 + b_2 \geq 1, d_2 \geq 1, ad_2 + b_1 \geq 1 \text{ and}$$

$$ad_1d_2 + b_1d_1 + b_2d_2 + c \geq 0. \quad (4.2)$$

We set $d_1^+ = \max(1, \lceil \frac{1-b_1}{a} \rceil)$ and $d_2^+ = \max(1, \lceil \frac{1-b_2}{a} \rceil)$. It is clear that if $\mathbf{d} \in \mathcal{D}_{\geq 0}(f)$, then $\mathbf{d} \geq (d_1^+, d_2^+)$. On the other hand, if $(d_1, d_2) \geq (d_1^+, d_2^+)$, then the only condition left for \mathbf{d} to be in $\mathcal{D}_{\geq 0}(f)$ is condition 4.2. Therefore, if

$$ad_1^+d_2^+ + b_1d_1^+ + b_2d_2^+ + c \geq 0, \text{ then } \min\mathcal{D}_{\geq 0}(f) = \{(d_1^+, d_2^+)\}.$$

Henceforth, let us assume that

$$ad_1^+d_2^+ + b_1d_1^+ + b_2d_2^+ + c < 0 \ (\leq -1) \quad (4.3)$$

and

$$ad_1d_2^+ + b_1d_1 + b_2d_2^+ + c < 0. \quad (4.4)$$

Thus

$$d_1^+ \leq d_1 < \frac{-(c + b_2d_2^+)}{ad_2^+ + b_1}$$

and in order to fulfill condition 4.2, we have that $d_2 \geq \frac{-(c+b_1d_1)}{ad+b_2}$. Also note that $\max \left(d_2^+, \frac{-(c+b_1d_1)}{ad_1+b_2} \right) = \frac{-(c+b_1d_1)}{ad_1+b_2}$ by 4.4. Then

$$\min \left\{ \left(d_1, \left\lceil \frac{-(c + b_1d_1)}{ad_1 + b_2} \right\rceil \right) \mid d_1^+ \leq d_1 \leq \left\lceil \frac{-(c + b_2d_2^+)}{ad_2^+ + b_1} \right\rceil \right\} \subseteq \min\mathcal{D}_{\geq 0}(f).$$

Finally, if

$$ad_1d_2^+ + b_1d_1 + b_2d_2^+ + c \geq 0, \quad (4.5)$$

then we have that $\max(d_2^+, \frac{-(c+b_1d_1)}{ad_1+b_2}) = d_2^+$ and

$$d_1 \geq \frac{-(c + b_2d_2^+)}{ad_2^+ + b_1}.$$

Thus

$$\left\{ \left(\left\lceil \frac{-(c + b_2 d_2^+)}{ad_2^+ + b_1} \right\rceil, d_2^+ \right) \right\} = \min \{ \mathbf{d} \in \mathcal{D}_{\geq 0}(f) \mid 4.3 \text{ and } 4.5 \text{ holds} \}.$$

We conclude that if 4.3 holds then $\min \mathcal{D}_{\geq 0}(f)$ is equal to the set of minimal elements of

$$\left\{ \left\{ \left(d, \left\lceil \frac{-(c + b_1 d)}{ad + b_2} \right\rceil \right) \mid d_1^+ \leq d \leq \left\lfloor \frac{-(c + b_2 d_2^+)}{ad_2^+ + b_1} \right\rfloor \right\} \cup \left\{ \left(\left\lceil \frac{-(c + b_2 d_2^+)}{ad_2^+ + b_1} \right\rceil, d_2^+ \right) \right\} \right\}.$$

On the other hand, if condition 4.3 is not fulfilled then $\min \mathcal{D}_{\geq 0}(f)$ is simply $\{(d_1^+, d_2^+)\}$. Clearly, this can be restated so that we have the result. \square

Remark 4.3.4. Note that $\mathcal{D}_{\geq 0}(f)$ is an infinite set. Moreover, we have monotonicity of f as in to Theorem 3.2.4. More precisely, if $g(x_1, x_2) = f(x_1 + d_1^+, x_2 + d_2^+)$ has positive non-constant coefficients, then

$$g(x_1 + \epsilon'_1, x_2 + \epsilon'_2) > g(x_1 + \epsilon_1, x_2 + \epsilon_2) > g(x_1, x_2)$$

for every $(\epsilon'_1, \epsilon'_2) > (\epsilon_1, \epsilon_2) > 0$.

Example 4.3.5. Let $f = f(x_1, x_2) = 2x_1x_2 - 7x_1 - 10x_2 + 16$ and let d_1^+ and d_2^+ be as in Lemma 4.3.3. It is not difficult to check that $(d_1^+, d_2^+) = (6, 4)$ and

$$\begin{aligned} \min \mathcal{D}_{\geq 0}(f) &= \min \left\{ \left(d, \max \left(4, \left\lceil \frac{-(16 - 7d)}{2d - 10} \right\rceil \right) \right) \mid d \in \mathbb{N}_+, 6 \leq d \leq 24 \right\} \\ &= \min \left\{ \begin{array}{l} (6, 13), (7, 9), (8, 7), (9, 6), (10, 6), (11, 6), (12, 5), (13, 5), (14, 5), (15, 5), \\ (16, 5), (17, 5), (18, 5), (19, 5), (20, 5), (21, 5), (22, 5), (23, 5), (24, 4) \end{array} \right\} \\ &= \left\{ \begin{array}{l} (6, 13), (7, 9), (8, 7), \\ (9, 6), (12, 5), (24, 4) \end{array} \right\}. \end{aligned}$$

And therefore $\mathcal{D}(f) = \{(6, 13), (24, 4)\}$.

Now we proceed to prove that the Algorithm 4.3.1 is correct.

Theorem 4.3.6. Algorithm 4.3.1 computes the sets $\min \mathcal{D}_{\geq 0}(f)$ and $\mathcal{D}(f)$ for any square-free dominated polynomial $f \in \mathbb{Z}[X]^*$.

Proof. First, note that induction on the size of L and the $n - 1$ minors of $(\text{Diag}(X + \mathbf{d}) - L)$ correspond to induction on the number of variables in X and the first partial derivatives of f respectively. Thus, if $f(X) = f_{L, \mathbf{d}}(X)$ for some non-negative matrix L , then by Proposition 3.2.3 the result follows by similar arguments of those given in Theorem 3.3.4.

In general, we can also proceed by induction, but now on the number of variables in X . When $|X| = 2$ and $f = f(X)$ is a square-free dominated polynomial with positive leading coefficient. Assume without loss of generality that $X = \{x_1, x_2\}$. Then $f = ax_1x_2 + b_1x_1 + b_2x_2 + c$ and by Lemma 4.3.3, $\min \mathcal{D}_{\geq 0}(f)$ is determined.

Now assume that the result holds for every polynomial on $2 \leq k \leq n-1$ variables. Let $f(x_1, \dots, x_n)$ be an integer square-free dominated polynomial with positive leading coefficient. Given any vector \mathbf{d}' in step (6) every coefficient of every monomial of degree at least 2 in $f(x_1 + d'_1, \dots, x_n + d'_n)$ is positive. Also every coefficient of every monomial of degree one in $f(x_1 + d'_1, \dots, x_n + d'_n)$ is non-negative. Whereas the independent term can be negative. But in steps (7) through (15) it is shown how to find the first vector $\mathbf{d} \geq \mathbf{d}'$ such that the independent term turns non-negative and the coefficients of the degree one monomials are positive too. That is, $\mathbf{d} \in \mathcal{D}_{\geq 0}(f)$.

At step (16) we proceed in the same manner as in Algorithm 3.3.3 to produce the set of minimal elements of $\mathcal{D}_{\geq 0}(f)$. Thus, we need to prove that every $\mathbf{d} \in \min \mathcal{D}_{\geq 0}(f)$ is reachable from some vector of the form given in step (6). Again, in a similar way as in the proof of theorem 3.3.4. Now, for every $\mathbf{d} \in \mathcal{D}_{\geq 0}(f)$, let $\mathbf{d}_{|s}$ be the vector equal to \mathbf{d} without the s -th entry. That is,

$$(\mathbf{d}_{|s})_i = \begin{cases} \mathbf{d}_i, & \text{if } 1 \leq i \leq s-1, \\ \mathbf{d}_{i+1}, & \text{if } s \leq i \leq n-1. \end{cases}$$

Then for every integer $1 \leq s \leq n$ we have that $\mathbf{d}_{|s} \in \mathcal{D}_{\geq 0}\left(\frac{\partial f}{\partial x_s}\right)$ and that there exists $\tilde{\mathbf{d}} \in \min \mathcal{D}_{\geq 0}\left(\frac{\partial f}{\partial x_s}\right)$ such that $\tilde{\mathbf{d}} \leq \mathbf{d}_{|s}$. Thus,

$$\max_{s \in [n]} \left\{ (\tilde{\mathbf{d}}^{(s)})_i \right\} \leq \mathbf{d}_i,$$

where $\mathbf{d}^{(s)}$ is as in (3.1). Therefore the algorithm computes $\min \mathcal{D}_{\geq 0}(f)$ and then is clear that it computes $\mathcal{D}(f)$ by definition. \square

We show the geometry intuition behind the statement of Lemma 4.3.3 through Example 4.3.5, see Figure 4.3. Let us denote the green region as P_G . Note that P_G corresponds to $\mathcal{D}_{\geq 0}(f)$ since it is the portion of the \mathbb{N}_+ -grid "above" (d_1^+, d_2^+) and such that $f \geq 0$. More precisely, $\mathcal{D}_{\geq 0}(f) = P_G \cap \mathbb{N}_+^2$. Furthermore, it is not difficult to see that if g is a polynomial of degree n then $\mathcal{D}_{\geq 0}(g) = P \cap \mathbb{N}_+^n$, where P is an unbounded n -dimensional polytope.

In the next example we can see how the Algorithm 4.3.1 works on a polynomial not in $\mathbb{MIP}[X]$.

Example 4.3.7. *Let*

$$f = x_1 x_2 x_3 - 19x_1 + 2x_2 + 3x_3 - 23$$

be the irreducible polynomial given in Example 4.2.6. Step (2) of Algorithm 4.3.1 gives us

$$\partial_1 f = x_2 x_3 - 19 \quad \partial_2 f = x_1 x_3 + 2 \quad \partial_3 f = x_1 x_2 + 3.$$

From step (3) and Lemma 4.3.3 we get that $\min \mathcal{D}_{\geq 0}(\partial_2 f) = \min \mathcal{D}_{\geq 0}(\partial_3 f) = \{(1, 1)\}$ and

$$\min \mathcal{D}_{\geq 0}(\partial_1 f) = \{(1, 19), (19, 1), (2, 10), (10, 2), (3, 7), (7, 3), (4, 5), (5, 4)\}.$$

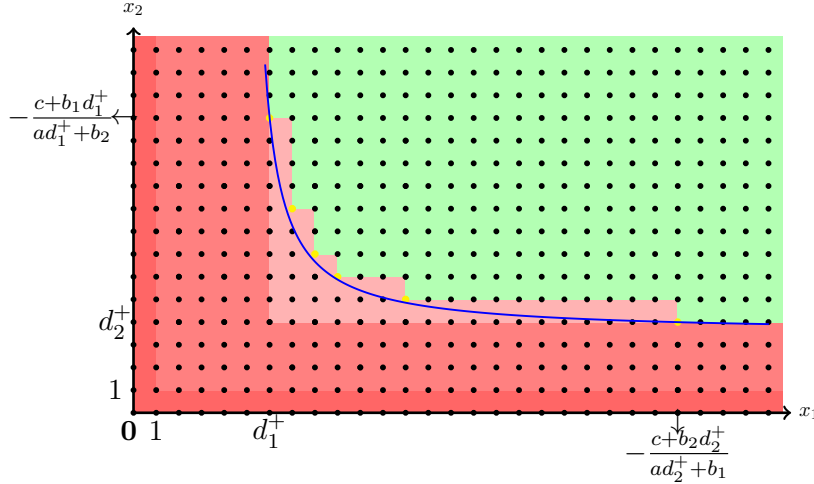

Figure 4.2: The blue line represents the curve $f = 2x_1x_2 - 7x_1 - 10x_2 + 16 = 0$ for $x_1 \geq 5.8$ and the yellow points are the elements in $\min\mathcal{D}_{\geq 0}(f)$.

Continuing with steps (4) to (6) we have the following set of \mathbf{d} 's to search,

$$\Pi = \left\{ \begin{array}{cccc} (1, 1, 19) & (1, 2, 10) & (1, 3, 7) & (1, 4, 5) \\ (1, 19, 1) & (1, 10, 2) & (1, 7, 3) & (1, 5, 4) \end{array} \right\}.$$

Note that $f_{\mathbf{d}}(X)$ has positive independent term for almost every vector $\mathbf{d} \in \Pi$, except for $(1, 5, 4)$. That is, only the vector $(1, 5, 4)$ has the chance to be an arithmetical structure of f . Indeed, since

$$f_{(1,5,4)}(X) = x_1x_2x_3 + 4x_1x_2 + 5x_1x_3 + x_2x_3 + x_1 + 6x_2 + 8x_3 + 0,$$

then $\mathcal{D}(f) = \{(1, 5, 4)\}$.

We recall that if f is a square-free dominated polynomial without any arithmetical structure, then this does not implies that $f = 0$ has not integer solutions.

Example 4.3.8. Let $g = x_1x_2 + 17x_1 - 12x_2 + 27$. By Lemma 4.3.3 we have that

$$\min\mathcal{D}_{\geq 0}(g) = \{(13, 1)\}.$$

On the other hand, since $g(13, 1) = 249$, then $\mathcal{D}(g) = \emptyset$. Nevertheless $g = 0$ has sixteen different solutions in \mathbb{Z}^2 . Moreover four of them are solutions in \mathbb{N}_+^2 , namely

$$\{(1, 4), (5, 16), (9, 60), (11, 214)\}.$$

None of them found by the algorithm. Because the condition of having all non-constant coefficients positive is not fulfilled by any of them. For instance note that

$$f(x_1 + 11, x_2 + 214) = x_1x_2 + 231x_1 - x_2.$$

4.4. Integer solutions of dominated polynomials

We will finish this chapter by exploring some ideas to obtain all the integer solutions of a dominated polynomial in an efficient way. Let us note that even though the set $\min\mathcal{D}_{\geq 0}(g)$ does not necessarily contain all its positive integer solutions of the polynomial g . As the next example illustrates, in some cases the coefficients of $g_{\mathbf{d}}(X)$ and $\min\mathcal{D}_{\geq 0}(g)$ gives us enough information to get all the integer solutions of a polynomial. This suggests that what we have developed so far is useful beyond finding arithmetical structures.

Example 4.4.1. *Following last Example 4.3.8 we have that for the polynomial*

$$g(x_1, x_2) = x_1x_2 + 17x_1 - 12x_2 + 27, \text{ then } \min\mathcal{D}_{\geq 0}(g) = \{(13, 1)\}.$$

Thus, $g(\mathbf{d}) \neq 0$ for all $\mathbf{d} \geq (13, 1)$. Moreover, it is not difficult to check that

$$g(x_1 + 13, x_2 + 1) = x_1x_2 + 18x_1 + x_2 + 236$$

and therefore its coefficients are positive. Therefore it only remains to check which vectors in

$$\{(d_1, d_2) \in \mathbb{N}^2 \mid d_1 \leq 12 \text{ and } d_2 \geq 1\}$$

are solutions of g .

First, since the coefficient of x_2 in

$$g(x_1 + 12, x_2 + 1) = x_1x_2 + 18x_1 + 231 \neq 0$$

is equal to zero, then $g(\mathbf{d}) \neq 0$ for all \mathbf{d} with $d_1 = 12$ and $d_2 \geq 1$. In a similar way, since

$$g(x_1 + 11, x_2 + 1) = x_1x_2 + 18x_1 - x_2 + 213$$

it is not difficult to see that the line segment $\{(11, a) \mid a \in \mathbb{N}_+\}$ contains at most one solution of $g = 0$, namely $(11, 214)$. Following this procedure we have that

$$g(x_1 + 10, x_2 + 1) = x_1x_2 + 18x_1 - 2x_2 + 195,$$

and evidently the line segment $\{(10, a) \mid a \in \mathbb{N}_+\}$ does not contain any solution of $g = 0$. Finally, in the other cases we get that $(9, 60)$, $(5, 16)$ and $(1, 4)$ are the other positive integer solutions of g . That is, $(11, 214)$, $(9, 60)$, $(5, 16)$ and $(1, 4)$ are the only positive integer solutions of g .

Remark 4.4.2. *In the general case when for $|X| = k + 1 \geq 3$ instead of looking the solution in a line segment we need to search in subsets of k -dimensional hyperplanes. Which can be done by using the same techniques presented here, but in a problem with one dimension less.*

Unfortunately, this technique does not work in general. We know that arithmetical structures of irreducible dominated square-free polynomials generalizes the concept for irreducible non-negative matrices with zero diagonal by Theorem 3.1.5. On the other hand, if we consider irreducible matrices with some negative off-diagonal entries and diagonal zero, then having a positive vector in the kernel does not implies positive principal minors.

Example 4.4.3. Resuming Example 3.2.6, consider the matrix

$$L = \begin{pmatrix} 0 & 3 & -1 \\ 0 & 0 & 2 \\ 1 & 1 & 0 \end{pmatrix} \text{ and } K_a = \begin{pmatrix} 0 & 3 & 0 \\ 0 & 0 & 2 \\ -a & 1 & 0 \end{pmatrix}.$$

Taking $\mathbf{d} = (6a, 1, 1)$, $\mathbf{r} = (1, 2a, a)$, we can see that $\mathbf{r} > 0$ and $\det(\text{Diag}(\mathbf{d}) - K_a) = 0$.

However, as we checked in Example 3.2.6, not all its principal minors are positive. Furthermore, taking

$$f_{K_a} := f_{K_a}(x_1, x_2, x_3) = \det(\text{Diag}(x_1, x_2, x_3) - K_a),$$

$f_{K_a} = x_1x_2x_3 - 2x_1 + 6a$ for every $a \in \mathbb{N}_+$. Therefore

$$\mathcal{D}_{\geq 0}(f_{K_a}) = \{(1, 1, 3), (1, 3, 1), (1, 2, 2)\} \text{ and } \mathcal{D}(f_{K_a}) = \emptyset$$

for every positive integer a . However, applying the previous heuristic given in Example 4.4.1, we can only find the positive solutions $(6a, 1, 1)$ for each $a \in \mathbb{N}_+$ given in Example 3.2.6.

The next example shows that the procedure used before not always get all the positive integers solutions even of a dominated polynomial. Let B an irreducible integer square matrix with some negative off-diagonal entries and diagonal zero. Defining the arithmetical structures on B in terms of the non-negativity of its minors seems to be the best option. In this way, we would be generalizing the concepts of almost non-singular (quasi non-singular) M -matrices to almost (quasi) P -matrices. The latter refers to the set of real matrices with positive proper principal minors and zero (indistinct) determinant.

Example 4.4.4. Applying Algorithm 4.3.1 to $f(x, y, z) = xyz - 17x + 8y - 12z - 27$ we get that $\mathcal{D}(f)$ is equal to

$$\{(3, 6, 5), (5, 4, 10), (7, 2, 65), (13, 1, 240), (15, 6, 3), (75, 3, 6), (119, 2, 9), (235, 1, 18)\}.$$

Note that $\{(1, 8, 5), (1, 10, 18), (1, 11, 44), (13, 8, 2), (89, 16, 1)\}$ are solutions of f which are not d -arithmetical structures. However, starting from the arithmetical structure $(3, 6, 5)$ and searching in set $\{(1, a, b) \mid a \geq 6, b \geq 5\}$ as in previous Example 3.2.6 we get the solutions

$$(1, 8, 5) \leq (1, 10, 18) \leq (1, 11, 44).$$

However, none of these methods are useful in general. Now, we present an example where we do not find all the positive integer solutions.

Example 4.4.5. Consider $f = zx_1x_2y_1y_2 - x_1x_2y_1y_2 + x_1x_2 - 7y_1y_2 - 1$. Thus the set of positive solutions of $f(z = 1) = x_1x_2 - 7y_1y_2 - 1 = 0$ contains the positive solutions of the Pell's equation

$$x^2 - 7y^2 = 1. \tag{4.6}$$

It is well known that the solutions of a Pell's equation are an infinite strictly increasing sequence of vectors. Moreover, if $\{(\alpha_n, \beta_n) | n \in \mathbb{N}\}$ are the solution of (4.6) ordered in increasing order, then they satisfy the following recurrent relation

$$\alpha_{k+1} = 16\alpha_k - \alpha_{k-1} \text{ and } \beta_{k+1} = 16\beta_k - \alpha_{k-1} \text{ for } k \geq 1.$$

More precisely, in our case we get the solutions

$$(8, 3), (127, 48), (2024, 765), (32257, 12192), (514088, 194307), \\ (8193151, 3096720), (130576328, 49353213) \text{ and so on } \dots$$

Thus, even when our methods are sufficient to find the arithmetical structures of a square-free dominated polynomial, in general it cannot find all the positive integer solutions of a monic square free polynomial, for instance the solutions of a Pell's equation. Therefore it is clear that our methods do not give us all integer solutions in general.

Defining arithmetical structures for dominated polynomials, not necessarily square-free, is very simple. More precisely, let

$$F(x_1, \dots, x_m) = 0$$

be a dominated Diophantine equation and let $\delta(i)$ be the maximum exponent of x_i in any term of F . Then let

$$f(x_{1_1}, \dots, x_{1_{\delta(1)}}, \dots, x_{m_1}, \dots, x_{m_{\delta(m)}}) = 0,$$

be a dominated square-free Diophantine equation such that

$$f(x_{1_1}, \dots, x_1, \dots, x_m, \dots, x_m) = F(x_1, \dots, x_m).$$

Thus

$$\mathcal{D}(F) := \left\{ (d_1, \dots, d_m) \mid \mathbf{d}' \in \mathcal{D}(f) \text{ such that } \mathbf{d}'_{i_1} = \dots = \mathbf{d}'_{i_{\delta(i)}} \text{ for every } i = 1, \dots, m \right\}.$$

Similarly for $\mathcal{D}_{\geq 0}(F)$. For instance, let $a \in \mathbb{N}_+$ and $F(x, y) = xy^2 - 2x + 6a$, then $\min \mathcal{D}_{\geq 0}(F) = \{(1, 2)\}$ and $\mathcal{D}(F) = \emptyset$ by the second part of Example 4.4.3. Furthermore, we can find the only solution for $F=0$ in $\mathbb{N}_+ \times \mathbb{N}_+$, $x = 6a$ and $y = 1$. Finally, considering

$$\mathcal{D}_{\geq \alpha}(F) = \left\{ \mathbf{d} \in \mathbb{N}_+^2 \mid F(X + \mathbf{d}) \text{ has positive non-constant coefficients and } F(\mathbf{d}) \geq \alpha \right\}$$

we can address solutions of the equation $F = \alpha$ for any $\alpha \in \mathbb{R}$. Therefore finding the arithmetical structures (and general solutions for that matter) of dominated Diophantine polynomials is a special case of square-free dominated Diophantine polynomials.

APPLICATIONS OF DETERMINANTAL
IDEALS OF GRAPHS

The structure of sandpile groups of outerplanar graphs

In this chapter we will apply the critical ideals of the weak dual graphs of outerplanar graphs to describe their sandpile groups. We give this description by evaluating the critical ideals of these weak dual graphs. This evaluation is done at the vectors denoting the lengths of the cycle bounding the faces of the outerplanar graphs. It is known that the weak dual of an outerplanar graph is a forest. Moreover, the critical ideals of trees were carefully studied in [41]. Note that this method can be used for many other planar graphs that are homeomorphic to outerplanar graphs. Furthermore, we will compute the critical configurations associated with the identity element of the sandpile group of the dual graph of an outerplane graph.

First, let us recall the dynamics of the sandpile model. It was firstly studied by Bak, Tang and Wiesenfeld in [18], and it is carried out on a simple connected graph G with a special vertex q , called sink. We denote by \mathbb{N} the set of non-negative integers. A configuration on (G, q) is a vector $c \in \mathbb{N}^V$, in which entry c_v is associated with the number of *grains of sand* or *chips* placed on vertex v . Two configurations c and d are *equal* if $c_v = d_v$ for each non-sink vertex. The sink vertex is used to collect the sand getting out the system. A non-sink vertex v is called *stable* if c_v is less than its degree $d_G(v)$, and *unstable*, otherwise. Thus, a configuration is called *stable* if every non-sink vertex is stable. The *toppling rule* in the dynamics of the sandpile model consists in selecting an unstable non-sink vertex u and moving $d_G(u)$ grains of sand from u to its neighbors, in which each neighbor v receives $m_{(u,v)}$ grains of sand, where $m_{(u,v)}$ denotes the number of edges between u to v . Note that toppling vertex v_i in configuration c corresponds to the subtraction the i -th row of the Laplacian matrix to c . Recall the Laplacian matrix $L(G)$ of a graph G is given such that the (u, v) -entry of $L(G)$ is defined as

$$L(G)_{u,v} = \begin{cases} \deg_G(u) & \text{if } u = v, \\ -m(u, v) & \text{otherwise.} \end{cases}$$

Starting with any unstable configuration and toppling unstable vertices repeatedly,

we will always obtain a stable and unique configuration after a finite sequence of topplings, [66, Theorem 2.2.2] and [26]. The stable configuration obtained from the configuration c will be denoted by $s(c)$. The sum of two configurations c and d is performed entry by entry. A configuration c is critical if there exists a non-zero configuration d such that $c = s(d + c)$. Let $c \oplus d := s(c + d)$. Critical configurations play a central role in the dynamics of the sandpile model since critical configurations together with the \oplus operation form an Abelian group known as sandpile group [66, Chapter 4]. Critical configurations are precisely the recurrent configurations of the dynamical system the sandpile model is describing. In the following $K(G)$ denotes the sandpile group of G . One of the interesting features of the sandpile group of connected graphs is that the order $|K(G)|$ is equal to the number $\tau(G)$ of spanning trees of the graph G .

Let us recall that the sandpile group of a graph is isomorphic to the cokernel of its Laplacian matrix. Furthermore, we recall that the algebraic structure of the sandpile group does not depend on the sink vertex, meanwhile the combinatorial structure depicted by the critical configurations of G do depend on the sink vertex.

The sandpile group has been studied under different names. We recommend the reader the book [66] which is an excellent reference on the theory of the sandpile model (chip-firing game) and its relations with other combinatorial objects like rotor-routing, hyperplane arrangements, parking functions and dominoes, etc. In particular, the properties of the critical configurations are explained in detail there.

The minimal number of generators of the torsion part of the cokernel of M equals the number of invariant factors of its Smith normal form ($\text{SNF}(M)$) greater than 1.

Let $\delta_1(G)$ and $\kappa(G)$ denote the number of invariant factors of $\text{SNF}(L(G))$ equal to 1 and the minimal number of generators of $K(G)$, respectively. If G is a graph with n vertices and c connected components, then $n - c = \delta_1(G) + \kappa(G)$.

Let us recall that, for $k \in [n]$, the k -th critical ideal $I_k(G, X_G)$ of a graph G is the ideal in $\mathbb{Z}[X]$ generated by the k -minors of the generalized Laplacian matrix $L(G, X_G)$. Henceforth we will write simply denoted the k -th critical ideal of G as $I_k(G)$. Note the evaluation of the k -th critical ideal of G at $X_G = \text{deg}(G)$ will be an ideal in \mathbb{Z} generated by $\Delta_k(L(G))$. We will show a new application of the critical ideals for computing the sandpile group of planar graphs. In this context the theorem of elementary divisors is very helpful to compute the invariant factors of a matrix M . Here we state it as a lemma

Lemma 5.0.1. [61, Theorem 3.9] *For $k \in [\text{rank}(M)]$, let $\Delta_k(M)$ be the gcd of the k -minors of matrix M , and $\Delta_0(M) = 1$. Then the k -th invariant factor $d_k(M)$ of M equals*

$$\frac{\Delta_k(M)}{\Delta_{k-1}(M)}.$$

When the graph is connected, it is convenient to compute the cokernel of a reduced Laplacian matrix since it is full rank. The reduced Laplacian matrix $L_k(G)$ for a connected graph G is the $(n - 1) \times (n - 1)$ matrix obtained by deleting the row and column k from $L(G)$. There are n different reduced Laplacian matrices and $K(G) \cong$

$\text{coker}(L_k(G))$ and $|K(G)| = \det(L_k(G)) = \tau(G)$ for any $k \in [n] := \{1, \dots, n\}$, see details in [26].

We will use G^* to denote the dual of a plane graph G , and the weak dual, denoted by G_* , is constructed the same way as the dual graph, but without placing the vertex associated with the outer face. It is known [25, 39, 92] that the sandpile group of a planar graph is isomorphic to the sandpile group of its dual. Since the dual of any plane graph is connected [28], then $K(G) \cong \text{coker}(L_k(G^*))$ and $\tau(G) = \det(L_k(G^*))$.

In [81], C. Phifer gave a nice interpretation of this relation by introducing the *cycle-intersection matrix* of a plane graph as follows. Given a plane graph G with s interior faces F_1, \dots, F_s , let $c(F_i)$ denote the length of the cycle which bounds interior face F_i . We define the *cycle-intersection matrix*, $C(G) = (c_{ij})$ to be a symmetric matrix of size $s \times s$, where $c_{ii} = c(F_i)$, and c_{ij} is the negative of the number of common edges in the cycles bounding the interior faces F_i and F_j , for $i \neq j$. Note that $C(G)$ is the reduced Laplacian of G^* where the column and row associated with the outer face are removed from $L(G^*)$. Therefore we have the following.

Lemma 5.0.2. *Let G be a plane graph. Then*

$$K(G) \cong \text{coker}(C(G)) \text{ and } \tau(G) = \det(C(G)).$$

Recently, the structure of the sandpile group of some subfamilies of the outerplanar graphs were established, see for example [22, 33, 67]. Also, the Tutte polynomial and the number of spanning trees of an infinite families of outerplanar, small-world and self-similar graphs were obtained in [38, 70]. Despite this, the algebraic structure of the sandpile groups of the outerplanar graphs have been largely unknown.

In Section 5.1, we explore the relation obtained in Lemma 5.0.2 under the lenses of the critical ideals of graphs. Then, we give a methodology to compute the algebraic structure of the sandpile groups of the plane graph family \mathcal{F} that have a common weak dual. This method consists in evaluating the indeterminates of the critical ideals of the weak dual at the lengths of the cycles bounding the interior faces of the plane graph in \mathcal{F} . In Section 5.2, we use this method and the property that the weak dual of outerplane graphs are trees, which was suggested by Chen and Mohar in [33], to compute the sandpile groups of outerplanar graphs. This result relies on previous results obtained by Corrales and Valencia in [41]. Finally, in Section 5.5, we compute the identity configuration for the sandpile groups of the dual graphs of many outerplane graphs.

5.1. Sandpile groups of planar graphs

In this section we will introduce a procedure that can be applied to compute the algebraic structure of the sandpile groups of the family of plane graphs that have a common weak dual graph in terms of the critical ideals of the common weak dual graph and the lengths of the cycles bounding the interior faces of a plane embedding.

The basic properties about critical ideals and determinantal ideals of graphs can be found in [2, 40], and in [7] can be found other applications of the critical ideals

not considered there. Now, let us state a few properties of the critical ideals. By convention $I_k(G) = \langle 1 \rangle$ if $k < 1$, and $I_k(G) = \langle 0 \rangle$ if $k > n$. An ideal is called *trivial* or *unit* if it is equal to $\langle 1 \rangle$. The algebraic co-rank of G , denoted by $\gamma(G)$, is the number of critical ideals of G equal to $\langle 1 \rangle$. It is known that if $i \leq j$, then $I_j(G) \subseteq I_i(G)$. Furthermore, if H is an induced subgraph of G , then $I_i(H) \subseteq I_i(G)$, from which follows that $\gamma(H) \leq \gamma(G)$.

The classic relation between critical ideals and the invariant factors of the sandpile groups of graphs are depicted by the following results. First, we recall an alternative way to compute the invariant factors of integer matrices derived from the adjacency matrix.

Lemma 5.1.1. [2, Proposition 14] *Let G be a graph with n vertices and the indeterminates of $X = (x_1, \dots, x_n)$ are associated with the vertices of G . Let $M = aI_n - A(G)$, where $a \in \mathbb{Z}^n$. Then, the ideal in \mathbb{Z} obtained from the evaluation of $I_k(G)$ at $X = a$ is generated by $\Delta_k(M)$, that is, the gcd of the k -minors of the matrix M .*

This result is very helpful since the k -th invariant factor $d_k(M)$ of the SNF of M is equal to $\frac{\Delta_k(M)}{\Delta_{k-1}(M)}$. In particular, we can apply Lemma 5.1.1 to the Laplacian matrix and reduced Laplacian matrix to give a method to compute the sandpile groups of some families of graphs.

Proposition 5.1.2. [40] *Let G be a graph with vertex set $\{v_1, \dots, v_n\}$. Then,*

1. *if $\deg(G) = (\deg_G(v_1), \dots, \deg_G(v_n))$, then the k -th critical ideal of G evaluated at $X = \deg(G)$ is generated by $\Delta_k(L(G))$, and the number of trivial critical ideals of G is at most the number of trivial invariant factors of the Laplacian of G , that is, $\gamma(G) \leq \delta_1(G)$,*
2. *let H be the graph constructed from G by adding a new vertex v_{n+1} , and let $m \in \mathbb{N}^n$, where m_i is the number of edges between v_{n+1} and v_i , then the k -th critical ideal of G evaluated at $X = \deg(G) + m$ is generated by $\Delta_k(L_{n+1}(H))$, and $\gamma(G) \leq f_1(H)$.*

Proof. It follows from Lemma 5.1.1, note that in case (1) the evaluation of $L(G, X)$ at $X = \deg(G)$ equals $L(G)$. Moreover, note that $\Delta_j(L(G)) = 1$ for all $1 \leq j \leq \gamma(G)$, therefore the first $\gamma(G)$ invariant factors are 1. In case (2) the evaluation of $L(G, X)$ at $X = \deg(G) + m$ equals $L_{n+1}(H)$ and similarly to case (1) we have that $f_1(H) \geq \gamma(G)$ \square

The next example will illustrate how the critical ideals can be used to compute the sandpile group of the family of graphs obtained from a graph G by adding a new vertex v with an arbitrary number of edges between v and the vertices of G .

Example 5.1.3. *Let H be the plane graph shown in Figure 5.1. Let C_8 be the cycle with 8 vertices obtained from H by removing vertex v_9 and the edges incident to it. The algebraic co-rank of C_8 is 6, and for the next critical ideal we will give their*

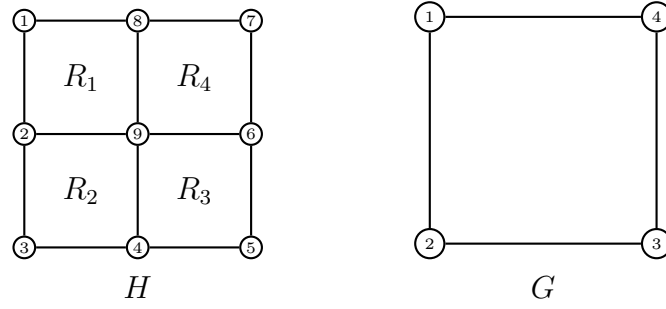

Figure 5.1: A plane graph H with 4 interior faces and its weak dual G .

Gröbner bases since we need a simple basis that describe the ideal. The Gröbner basis of the 7-th critical ideal of C_8 is generated by the following 3 polynomials:

$$\begin{aligned} p_1 &= x_1 + x_3x_4x_5x_6x_7 - x_3x_4x_5 - x_3x_4x_7 - x_3x_6x_7 + x_3 - x_5x_6x_7 + x_5 + x_7, \\ p_2 &= x_2 + x_4x_5x_6x_7x_8 - x_4x_5x_6 - x_4x_5x_8 - x_4x_7x_8 + x_4 - x_6x_7x_8 + x_6 + x_8, \\ p_3 &= x_3x_4x_5x_6x_7x_8 - x_3x_4x_5x_6 - x_3x_4x_5x_8 - x_3x_4x_7x_8 + \\ &\quad x_3x_4 - x_3x_6x_7x_8 + x_3x_6 + x_3x_8 - x_5x_6x_7x_8 + x_5x_6 + x_5x_8 + x_7x_8. \end{aligned}$$

The 8-th critical ideal of C_8 is generated by the determinant of $L(C_8, X)$:

$$\begin{aligned} &x_1x_2x_3x_4x_5x_6x_7x_8 - x_1x_2x_3x_4x_5x_6 - x_1x_2x_3x_4x_5x_8 - x_1x_2x_3x_4x_7x_8 \\ &+ x_1x_2x_3x_4 - x_1x_2x_3x_6x_7x_8 + x_1x_2x_3x_6 + x_1x_2x_3x_8 - x_1x_2x_5x_6x_7x_8 \\ &+ x_1x_2x_5x_6 + x_1x_2x_5x_8 + x_1x_2x_7x_8 - x_1x_2 - x_1x_4x_5x_6x_7x_8 + x_1x_4x_5x_6 \\ &+ x_1x_4x_5x_8 + x_1x_4x_7x_8 - x_1x_4 + x_1x_6x_7x_8 - x_1x_6 - x_1x_8 - x_2x_3x_4x_5x_6x_7 \\ &+ x_2x_3x_4x_5 + x_2x_3x_4x_7 + x_2x_3x_6x_7 - x_2x_3 + x_2x_5x_6x_7 - x_2x_5 - x_2x_7 \\ &- x_3x_4x_5x_6x_7x_8 + x_3x_4x_5x_6 + x_3x_4x_5x_8 + x_3x_4x_7x_8 - x_3x_4 + x_3x_6x_7x_8 - x_3x_6 \\ &- x_3x_8 + x_4x_5x_6x_7 - x_4x_5 - x_4x_7 + x_5x_6x_7x_8 - x_5x_6 - x_5x_8 - x_6x_7 - x_7x_8. \end{aligned}$$

In particular, by evaluating the polynomials p_1, p_2, p_3 and $\det(L(C_8, X))$ at

$$X = \deg(C_8) + (0, 1, 0, 1, 0, 1, 0, 1),$$

we obtain $\Delta_7(L_9(H)) = \gcd(32, 48, 72) = 8$, and $\Delta_8(L_9(H)) = 192$. From which follows that the sandpile group $K(H)$ is isomorphic to $\mathbb{Z}_8 \oplus \mathbb{Z}_{24}$.

The Gröbner basis for the critical ideals of the complete graphs, the cycles and the paths were computed in [40]. In [41], it was given a description of the generators of the k -th-critical ideal of any tree in terms of a set of special 2-matchings. The generators of the critical ideals of other graph families have been computed in [6, 8, 53].

A new relation is explored next based on the cycle-intersection matrix $C(H)$ of a plane graph H .

Theorem 5.1.4. *Let G be a graph with vertex set $\{v_1, \dots, v_n\}$. If G is the weak dual of the plane graph H and $c \in \mathbb{N}^n$ is such that c_i is the length of the cycle bounding the i -th finite face, then the ideal in \mathbb{Z} obtained from the evaluation of $I_k(G)$ at $X = c$ is generated by $\Delta_k(C(H))$. And $f_1(C(H)) \geq \gamma(G)$.*

Proof. We have that $G = H_*$. Let us assume that $v_{n+1} \in H^*$ is the vertex that corresponds to the outer face of H . Then $C(H)$ is the reduced Laplacian matrix $L_{n+1}(H^*)$. Now, set $c = \deg(G) + m$, where m_i is the number of edges between the vertex associated with the i -th interior face and the outer face. Thus the result follows by applying Proposition 5.1.2. \square

Let G be a plane graph. Therefore by Lemma 5.0.2 and Theorem 5.1.4, the sandpile group of any plane graph H having G as weak dual can be obtained from the critical ideals of G by evaluating the indeterminates $X = (x_1, \dots, x_n)$ at the lengths $c = (c_1, \dots, c_n)$ of the cycles bounding the interior faces of H . Also

$$\det(L(G, X))|_{X=c} = \tau(H).$$

Let us illustrate this with the following example.

Example 5.1.5. *Let G be the graph described in the right-hand side in Figure 5.1. Then*

$$A_Y(G) = \begin{bmatrix} y_1 & -1 & 0 & -1 \\ -1 & y_2 & -1 & 0 \\ 0 & -1 & y_3 & -1 \\ -1 & 0 & -1 & y_4 \end{bmatrix}.$$

Since there are 2-minors in $A_Y(G)$ equal to ± 1 , then $\gamma(G) \geq 2$, the equality follows since the third critical ideal of G is non-trivial. The Gröbner basis of $I_3(G)$ is

$$\langle y_1 + y_3, y_2 + y_4, y_3y_4 \rangle$$

Moreover,

$$I_4(G) = \langle \det(A_Y(G)) \rangle = \langle y_1y_2y_3y_4 - y_1y_2 - y_1y_4 - y_2y_3 - y_3y_4 \rangle.$$

Now, we will use these critical ideals to obtain the sandpile groups of any plane graph H whose weak dual is isomorphic to G . Thus, we only need to evaluate the indeterminates at the length of the cycles bounding the interior faces of H . Note that the length of the interior faces of H is at least 2 and at least one of the interior faces has length at least 3. One of such cases is when all interior faces of H have the same length, say t . Hence, for this case, $\Delta_3(C(H)) = \gcd(2t, t^2)$ and $\Delta_4(C(H)) = |t^4 - 4t^2|$. It is not difficult to see that $\Delta_3(C(H))$ is equal to t whenever t is odd and it is equal to $2t$ whenever t is even. Therefore, if the interior faces of H have the same length t , the sandpile group $K(H)$ of H is isomorphic to $\mathbb{Z}_{\gcd(2t, t^2)} \oplus \mathbb{Z}_{\frac{|t^4 - 4t^2|}{\gcd(2t, t^2)}}$ and $\tau(H) = |t^4 - 4t^2|$. Since $t \geq 3$, then the sandpile group of H is not cyclic.

5.2. Sandpile groups of outerplanar graphs

We recall that a graph is outerplanar if it has a planar embedding with the outer face containing all the vertices. An outerplanar graph equipped with such embedding is known as *outerplane graph*.

Lemma 5.2.1. [52] *A graph G is outerplanar if and only if it has a weak dual G_* which is a forest.*

One advantage of the outerplane graphs is that when the outerplanar has been embedded in the plane with all the vertices lying on the outer face, then the weak dual is the union of the weak duals of the blocks of G .

Next result implies that we should focus in computing sandpile groups of biconnected outerpanar graphs.

Lemma 5.2.2. [94] *Let G be a graph with b non-trivial blocks B_1, \dots, B_b . Then $K(G) \cong K(B_1) \oplus \dots \oplus K(B_b)$.*

The following result is an specialization of Lemma 5.2.1.

Corollary 5.2.3. *A graph G is biconnected outerplane if and only if its weak dual G_* is a tree.*

Now we will give a description of the generators of the critical ideals of any tree T , which were obtained in [41] in terms of the 2-matchings of the graph T^l , where T^l is the graph obtained from T by adding a loop at each vertex of T .

Recall that a *2-matching* is a set of edges $\mathcal{M} \subseteq E(G)$ such that every vertex of G is incident to at most two edges in \mathcal{M} and note that a loop counts as two incidences for its respective vertex. The set of 2-matchings of T^l with k edges is denoted by ${}_2\text{Mat}(T^l, k)$. Given a 2-matching \mathcal{M} of T^l , the loops $\ell(\mathcal{M})$ of \mathcal{M} is the edge set $\mathcal{M} \cap \{uu : u \in V(G)\}$. A 2-matching \mathcal{M} of T^l is *minimal* if there does not exist a 2-matching \mathcal{M}' of T^l such that $\ell(\mathcal{M}') \subsetneq \ell(\mathcal{M})$ and $|\mathcal{M}'| = |\mathcal{M}|$. The set of minimal 2-matchings of T^l will be denoted by ${}_2\text{Mat}^*(T^l)$, and the set of minimal 2-matchings of T^l with k edges will be denoted by ${}_2\text{Mat}_k^*(T^l)$. Let $d_X(T, \ell(\mathcal{M}))$ denote $\det(L(T, X)[V(\ell(\mathcal{M}))])$, that is, the determinant of the submatrix of $L(T, X)$ formed by selecting the columns and rows associated with the loops of \mathcal{M} . Assuming that it is clear that \mathcal{M} is a 2-matching of a certain tree T , then we will write simply $d_X(\ell(\mathcal{M}))$.

Lemma 5.2.4. [41, Theorem 3.7] *Let T be a tree with n vertices. Then*

$$I_k(T) = \langle \{d_X(\ell(\mathcal{M})) : \mathcal{M} \in {}_2\text{Mat}_k^*(T^l)\} \rangle,$$

for $k \in [n]$.

It follows directly from Theorem 5.1.4 and Lemma 5.2.4 that the sandpile groups of outerplanar graphs are determined in terms of the length of the cycles bounding the interior faces of their outerplane embeddings and the 2-matching of the weak dual with loops.

Theorem 5.2.5. *Let G be a biconnected outerplane graph whose weak dual is the tree T with n vertices, and let $c = (c_1, \dots, c_n)$ be the vector of the lengths of the cycles bounding the finite faces F_1, \dots, F_n . Let*

$$\Delta_k = \gcd(\{d_X(\ell(\mathcal{M}))|_{X=c} : \mathcal{M} \in {}_2\text{Mat}_k^*(T^l)\}),$$

for $k \in [n]$. Then $K(G) \cong \mathbb{Z}_{\Delta_1} \oplus \mathbb{Z}_{\frac{\Delta_2}{\Delta_1}} \oplus \dots \oplus \mathbb{Z}_{\frac{\Delta_n}{\Delta_{n-1}}}$ and $\tau(G) = \Delta_n$.

Let us illustrate the utility of Theorem 5.2.5 in the following example.

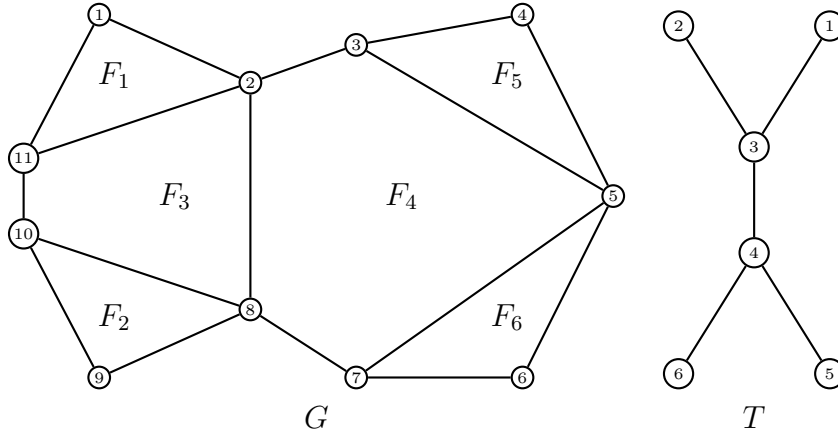

Figure 5.2: An outerplane graph G with 6 interior faces and its weak dual T .

Example 5.2.6. *Let G be the outerplane graph in Figure 5.2, then $G_* = T$ where the vertex $i \in V(T)$ corresponds to the face F_i of G for each $1 \leq i \leq 6$. We will use Theorem 5.2.5 to compute the sandpile group of $K(G)$. We need to compute ${}_2\text{Mat}_k^*(T^l)$ for $1 \leq k \leq 6$. First, note that if T^l has minimal 2-matching of size k without loops, then $I_k(T) = \langle 1 \rangle$. It is easy to see that this is the case for $k \leq 4$ and then $\Delta_1 = \Delta_2 = \Delta_3 = \Delta_4 = 1$. On the other hand, for $k = 5$,*

$${}_2\text{Mat}_5^*(T^l) = \left\{ \begin{array}{ll} \{(11), (22), (33), (45), (46)\}, & \{(13), (23), (44), (55), (66)\}, \\ \{(11), (55), (23), (34), (46)\}, & \{(11), (66), (23), (34), (45)\}, \\ \{(22), (55), (13), (34), (46)\}, & \{(22), (66), (13), (34), (45)\} \end{array} \right\}.$$

Therefore, by Lemma 5.2.4,

$$I_5(T^l) = \langle x_1x_2x_3 - x_1 - x_2, x_4x_5x_6 - x_5 - x_6, x_1x_5, x_1x_6, x_2x_5, x_2x_6 \rangle.$$

Moreover, the 6-th critical ideal of T is generated by $\det(L(T, X))$;

$$\begin{aligned} & x_1x_2x_3x_4x_6x_5 - x_1x_2x_3x_5 - x_1x_2x_3x_6 - x_1x_2x_6x_5 - x_1x_4x_6x_5 \\ & - x_2x_4x_6x_5 + x_1x_5 + x_2x_5 + x_1x_6 + x_2x_6 \end{aligned}$$

Now, since $c = (3, 3, 4, 5, 3, 3)$ and by Theorem 5.2.5, $\Delta_5 = \gcd(30, 39, 9) = 3$, $\Delta_6 = 1089$ and thus $K(G) = \mathbb{Z}_3 \oplus \mathbb{Z}_{363}$. Note that we can easily compute the sandpile

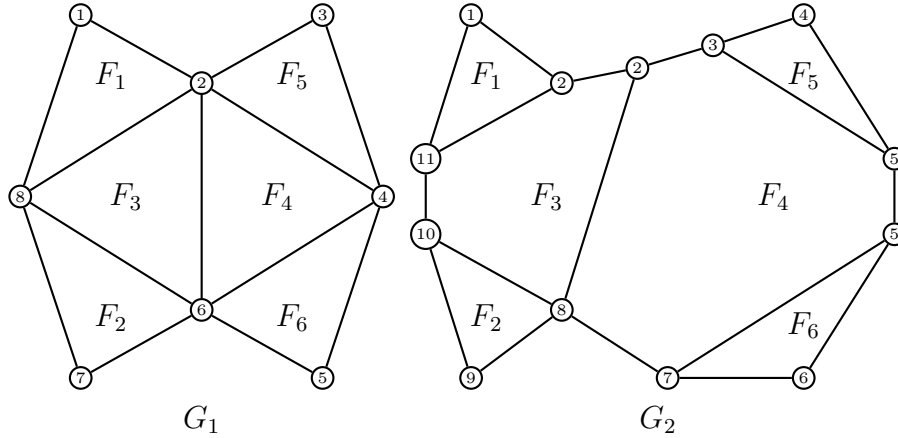

Figure 5.3: An outerplane graph G with 6 interior faces and its weak dual T .

group of any graph with T as its weak dual, using the corresponding cycle-lengths. For instance, some allowed edge contractions or vertex splittings of G as in Figure 5.3. Let $c_1 = (3, 3, 3, 3, 3, 3)$ and $c_2 = (3, 3, 5, 6, 3, 3)$ be the vectors of lengths of the cycles bounding the interior faces of G_1 and G_2 respectively. Then

$$K(G_1) = \mathbb{Z}_{\gcd(39,48,9)} \oplus \mathbb{Z}_{\frac{1791}{\gcd(39,48,9)}} = \mathbb{Z}_3 \oplus \mathbb{Z}_{597} \text{ and}$$

$$K(G_2) = \mathbb{Z}_{\gcd(21,9)} \oplus \mathbb{Z}_{\frac{360}{\gcd(21,9)}} = \mathbb{Z}_3 \oplus \mathbb{Z}_{120}.$$

Remark 5.2.7. Note that if G is a biconnected outerplane graph with weak dual T . Then any subdivision of the non-chordal edges of G is an outerplane graph with the same weak dual. Therefore, by Theorem 5.2.5, the algebraic structure of the sandpile groups of any such graph in the homeomorphism class of G is encoded in the combinatorial structure of T .

Moreover, if G is a biconnected outerplane graph whose weak dual is the tree T , then $\delta_1(C(G)) \geq \gamma(T)$. Let $\nu_2(G)$ denote the 2-matching number of G that is defined as the maximum number of edges of a 2-matching of G . It was proven in [41] that for any tree T , the equality $\gamma(T) = \nu_2(T)$ holds. Later, in [7] it was proven that $\nu_2(T) = n - \rho(T)$ for any tree T on n vertices, where the parameter $\rho(T)$ is defined as the maximum of $p - q$ such that by deleting q vertices from T the remaining graph becomes p paths. Since it was found a linear-time algorithm for finding $\rho(T)$ [63], it was concluded in [7] that there is a polynomial time algorithm to compute the algebraic co-rank for trees. Also, Alfaro and Lin proved that for any tree T , the algebraic co-rank $\gamma(T)$ coincides with the minimum rank $\text{mr}(T)$ of T and with $\text{mz}(T) := |V(T)| - Z(T)$, where $Z(T)$ denote the zero-forcing number of T .

In the following the sandpile groups of some outerplanar graphs are further simplified.

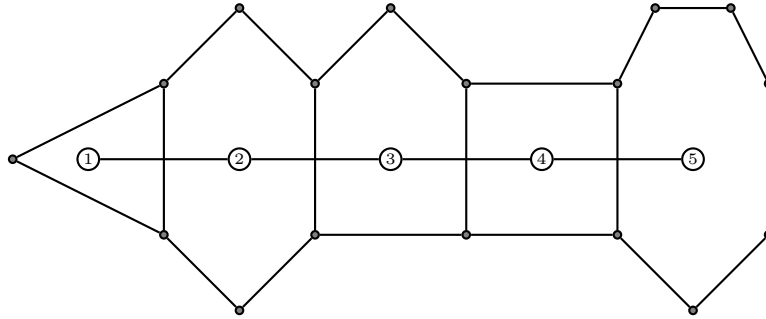

Figure 5.4: A polygon chain PC_4 defined by the sequence $(3, 6, 5, 4, 7)$.

5.3. Outerplane graphs whose weak dual is a path

Let us consider the outerplane graphs whose common weak dual is a path. Let (k_1, \dots, k_n) be a sequence of integers where each $k_i \geq 2$. Let PC_0 denote the path with one edge. For each $1 \leq i \leq n$, take the graph PC_i from the graph PC_{i-1} by adding a path with $k_i - 1$ edges between any pair of adjacent vertices of the path added in the construction of PC_{i-1} . Thus, the graph PC_n consists of a stack of n polygons with k_1, \dots, k_n sides. The graph PC_n is known as *polygon chain*. Polygon chains are the outerplanar graphs having the path as a weak dual. In Figure 5.4 we have an example of a polygon chain PC_4 . Note that the construction of polygon chains is not unique, that is, given an integer n and a sequence (k_1, \dots, k_n) , then there may exist non-isomorphic polygon chains defined by (k_1, \dots, k_n) .

It is not difficult to see that $\gamma(G) = n - 1$ if G is a path with n vertices. The opposite is also true, see [41, Corollary 3.9]. From which follows that polygon chains have cyclic sandpile group. The last critical ideal $I_n(P_n)$ of the path P_n with n vertices is generated by the determinant of $L(P_n, X)$. The following relations follow directly from the determinant of $L(P_n, X)$. These were already noticed in [22, 33, 67].

Lemma 5.3.1. *Let P_n be the path with n vertices and let $X = \{x_1, \dots, x_n\}$ a set of indeterminates associated with the vertices of P_n and let PC_n be a polygon chain defined by (k_1, \dots, k_n) . Then*

$$\det(L(P_n, X)) = x_n \det(L(P_{n-1}, X)) - \det(L(P_{n-2}, X))$$

$$\text{and } \tau(PC_n) = k_n \tau(PC_{n-1}) - \tau(PC_{n-2}).$$

In [40], an explicit computation of the determinant of $L(P_n, X)$ was obtained in terms of the matchings.

Lemma 5.3.2. [40, Corollary 4.5] *Let P_n be the path with n vertices. Then*

$$\det(L(P_n, X)) = \sum_{\mu \in \text{Mat}(P_n)} (-1)^{|\mu|} \prod_{v \notin V(\mu)} x_v,$$

where $\text{Mat}(P_n)$ is the set of matchings of P_n .

The following result derives directly from previous Lemma and Theorem 5.1.4.

Theorem 5.3.3. *Let PC_n be a polygon chain whose stack of polygons have k_1, \dots, k_n sides. Then the sandpile group $K(PC_n)$ of PC_n is cyclic of order*

$$\tau(PC_n) = \sum_{\mu \in \text{Mat}(P_n)} (-1)^{|\mu|} \prod_{v \notin V(\mu)} k_v,$$

where $\text{Mat}(P_n)$ is the set of matchings of P_n .

Now we proceed to analyze an special family of polygon chains. A polygon chain is called a *polygon ladder* if each of its polygons has the same number of sides.

Example 5.3.4. *Let PL_n^k be a polygon ladder consisting of n k -polygons with $k \geq 3$. By Theorem 5.3.3 its sandpile group is cyclic of order*

$$\tau(PL_n^k) = \sum_{\mu \in \text{Mat}(P_n)} (-1)^{|\mu|} \prod_{v \notin V(\mu)} k = \sum_{\mu \in \text{Mat}(P_n)} (-1)^{|\mu|} k^{n-2|\mu|}$$

Let $\nu(G)$ be the matching number of G . It is easy to check that the number of matchings of P_n of size i is $\binom{n-i}{i}$ for $i = 1, \dots, \nu(P_n)$. If n is even, say $n = 2m$ for some positive integer, then $\nu(P_n) = m$. Similarly, when n is odd. Assume $n = 2m + 1$ for some positive integer m , then $\nu(P_n) = m$. In both cases the matching number of P_n is $\lfloor n/2 \rfloor$. Therefore,

$$\tau(PL_n^k) = \sum_{i=0}^{\lfloor n/2 \rfloor} (-1)^i \binom{n-i}{i} k^{n-2i}, \text{ for } n \geq 1.$$

Since $0 < \frac{4}{k^2} < 1$, we have that

$$\tau(PL_n^k) = k^n {}_2F_1\left(\frac{1}{2} - \frac{n}{2}, -\frac{n}{2}; -n; \frac{4}{k^2}\right) \text{ for } n \geq 1,$$

where ${}_2F_1(a, b; c; x)$ is the Gauss's hypergeometric function. Now, let us present three more specific instances. First, let us address the case of $PL_n^4 = P_2 \square P_n$ (also known as the ladder graph or the $2 \times n$ grid). We have that $K(PL_n^4)$ is a cyclic group of order

$$\tau(PL_n^4) = \frac{1}{2\sqrt{3}} ((2 + \sqrt{3})^{n+1} - (2 - \sqrt{3})^{n+1}), \text{ for } n \geq 1.$$

On the other hand, consider PL_n^6 (also called as an hexagonal chain). Hence $K(PL_n^6)$ is a cyclic group of order

$$\tau(PL_n^6) = \frac{1}{4\sqrt{2}} ((3 + 2\sqrt{2})^{n+1} - (3 - 2\sqrt{2})^{n+1}), \text{ for } n \geq 1.$$

Lastly, consider a polygonal ladder with n octagons PL_n^8 . In this case we have that

$$\tau(PL_n^8) = \frac{1}{2\sqrt{15}} ((4 + \sqrt{15})^{n+1} - (4 - \sqrt{15})^{n+1}), \text{ for } n \geq 1.$$

In Table 5.1 we list the value of $|K(PL_n^k)|$ for $k = 4, 6, 8$ and $1 \leq n \leq 11$.

n	$\tau(PL_n^4)$	$\tau(PL_n^6)$	$\tau(PL_n^8)$
1	4	6	8
2	15	35	63
3	56	204	496
4	209	1189	3905
5	780	6930	30744
6	2911	40391	242047
7	10864	235416	1905632
8	40545	1372105	15003009
9	151316	7997214	118118440
10	564719	46611179	929944511
11	2107560	271669860	7321437648

Table 5.1: $\tau(PL_n^4)$, $\tau(PL_n^6)$ and $\tau(PL_n^8)$ for $1 \leq n \leq 11$

5.4. Outerplane graphs whose weak dual is a starlike tree

We denote by $S(n_1, \dots, n_l)$ a *starlike tree* in which removing the central vertex leaves disjoint paths P_{n_1}, \dots, P_{n_l} in which exactly one endpoint of each path is a leaf on $S(n_1, \dots, n_l)$.

Let $C_l = v_1 e_1 v_2 e_2 \dots v_l e_l v_1$ be a cycle of length l , and $PC_{n_1}, \dots, PC_{n_l}$ be l polygon chains. A *polygon flower* $F(C_l; PC_{n_1}, \dots, PC_{n_l})$ is constructed by identifying, for $i \in [l]$, the edges $e_i \in C_l$ and $e'_i \in PC_{n_i}$ such that e'_i is in the first or the last polygon of PC_{n_i} and is not contained in another polygon of this polygon chain. The weak dual of an outerplane embedding of polygon flowers are starlike trees.

Example 5.4.1. Let C_3 be the cycle on the vertex set $\{0, 1, 2\}$ and let $e_1 = (0, 1)$, $e_2 = (1, 2)$ and $e_3 = (2, 0)$ be its edges. Now let F_1 and F_2 be two graphs which can be drawn as follows

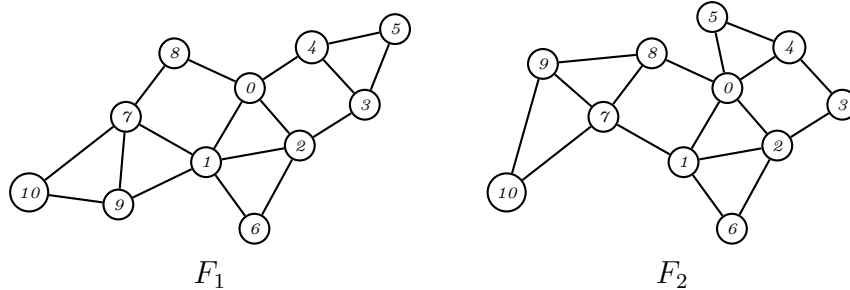

Then both F_1 and F_2 are defined by $F(C_3; PC_3, PC_1, PC_2)$ and the corresponding integer sequences $(4, 3, 3)$, (3) and $(4, 3)$. Let us note that F_1 and F_2 are not isomorphic.

The number of spanning trees of polygon flowers are closely related to the number of spanning trees of its polygon chains

Theorem 5.4.2. [33, Corollary 4.2] *Let $F = F(C_l; PC_{n_1}, \dots, PC_{n_l})$ be a polygon flower. Then*

$$\tau(F) = \left(\prod_{j=1}^l \tau(PC_{n_j}) \right) \sum_{i=1}^l \frac{\tau(PC_{n_i}/e_i)}{\tau(PC_{n_i})}$$

where PC_{n_i}/e_i denotes the graph obtained from PC_{n_i} by contracting the edge e_i .

Moreover, in [33] the sandpile group of the polygon flowers were obtained in terms of the spanning tree numbers of the polygon chains.

Lemma 5.4.3. [33, Theorem 4.3] *Let $F = F(C_l; PC_{n_1}, \dots, PC_{n_l})$ be a polygon flower. For $j \in [l-2]$, $\Delta_j = \gcd(\tau(PC_{n_{i_1}}) \cdots \tau(PC_{n_{i_j}}) : 1 \leq i_1 < \cdots < i_j \leq l)$. Then*

$$K(F) = \mathbb{Z}_{\Delta_1} \oplus \mathbb{Z}_{\frac{\Delta_2}{\Delta_1}} \oplus \cdots \oplus \mathbb{Z}_{\frac{\Delta_{l-2}}{\Delta_{l-3}}} \oplus \mathbb{Z}_{\frac{\tau(F)}{\Delta_{l-2}}}.$$

By Theorem 5.3.3, Lemma 5.4.3 can be stated in terms of matchings of the path and the length of the polygons as follows.

Theorem 5.4.4. *Let $F = F(C_l; PC_{n_1}, \dots, PC_{n_l})$ be a polygon flower, where $k_1^i, \dots, k_{n_i}^i$ are the sizes of the polygons of PC_{n_i} . Let*

$$\omega(n_i, k_1^i, \dots, k_{n_i}^i) = \sum_{\mu \in \text{Mat}(P_{n_i})} (-1)^{|\mu|} \prod_{v \notin V(\mu)} k_v^i.$$

For $j \in [l-2]$, $\Delta_j = \gcd(\omega(n_{i_1}, k_1^{i_1}, \dots, k_{n_{i_1}}^{i_1}) \cdots \omega(n_{i_j}, k_1^{i_j}, \dots, k_{n_{i_j}}^{i_j}) : 1 \leq i_1 < \cdots < i_j \leq l)$. Then

$$K(F) = \mathbb{Z}_{\Delta_1} \oplus \mathbb{Z}_{\frac{\Delta_2}{\Delta_1}} \oplus \cdots \oplus \mathbb{Z}_{\frac{\Delta_{l-2}}{\Delta_{l-3}}} \oplus \mathbb{Z}_{\frac{\tau(F)}{\Delta_{l-2}}}.$$

Finally, we complement Example 5.3.4 analyzing a certain polygon flower constructed with polygon ladders.

Example 5.4.5. *Let $F = F(C_5; PC_{n_1}, PC_{n_2}, PC_{n_3}, PC_{n_4}, PC_{n_5})$ be a polygon flower and set the polygon chains of F as $PC_{n_1} = PL_5^4$, $PC_{n_2} = PL_8^4$, $PC_{n_3} = PL_2^6$, $PC_{n_4} = PL_5^6$ and $PC_{n_5} = PL_5^8$. Moreover, if $1 \leq j \leq 5$ and $\tau(PC_{n_j}) = \tau(PL_n^k)$ with $n \geq 2$ and $k \geq 3$, by Lemma 5.3.1 we have that*

$$\tau(PC_{n_j}/e_j) = (k-1)\tau(PL_{n-1}^k) - \tau(PL_{n-2}^k) = \tau(PL_n^k) - \tau(PL_{n-1}^k)$$

Therefore, by Theorem 5.4.2 and using Table 5.1

$$\begin{aligned} \tau(F) &= \left(\prod_{j=1}^5 \tau(PC_{n_j}) \right) \sum_{i=1}^5 \frac{\tau(PC_{n_i}/e_i)}{\tau(PC_{n_i})} \\ &= (235827017145720000) \left(\frac{571}{780} + \frac{29681}{40545} + \frac{29}{35} + \frac{5741}{6930} + \frac{26839}{30744} \right). \end{aligned}$$

Hence, $\Delta_1 = 1$, $\Delta_2 = 15$, $\Delta_3 = 9450$ and $\tau(F) = 941912914331277000$. Thus the sandpile group of any polygon flower F is $\mathbb{Z}_{15} \oplus \mathbb{Z}_{630} \oplus \mathbb{Z}_{99673324267860}$.

5.5. Identity element of the sandpile group of outerplanar graphs

Throughout this section we will consider outerplane graphs to be biconnected unless otherwise stated. Determining the combinatorial structure of the critical configurations for outerplanar graph seems to be a more challenging problem since it depends on the sink vertex, and the sandpile groups are not always cyclic. However, we will consider the dual of an outerplane graph since the vertex associated with the outer face is a natural sink vertex, the weak dual is a tree and from a critical configuration of this dual graph we can recover the associated critical configurations of the outerplane graph with different sink vertices.

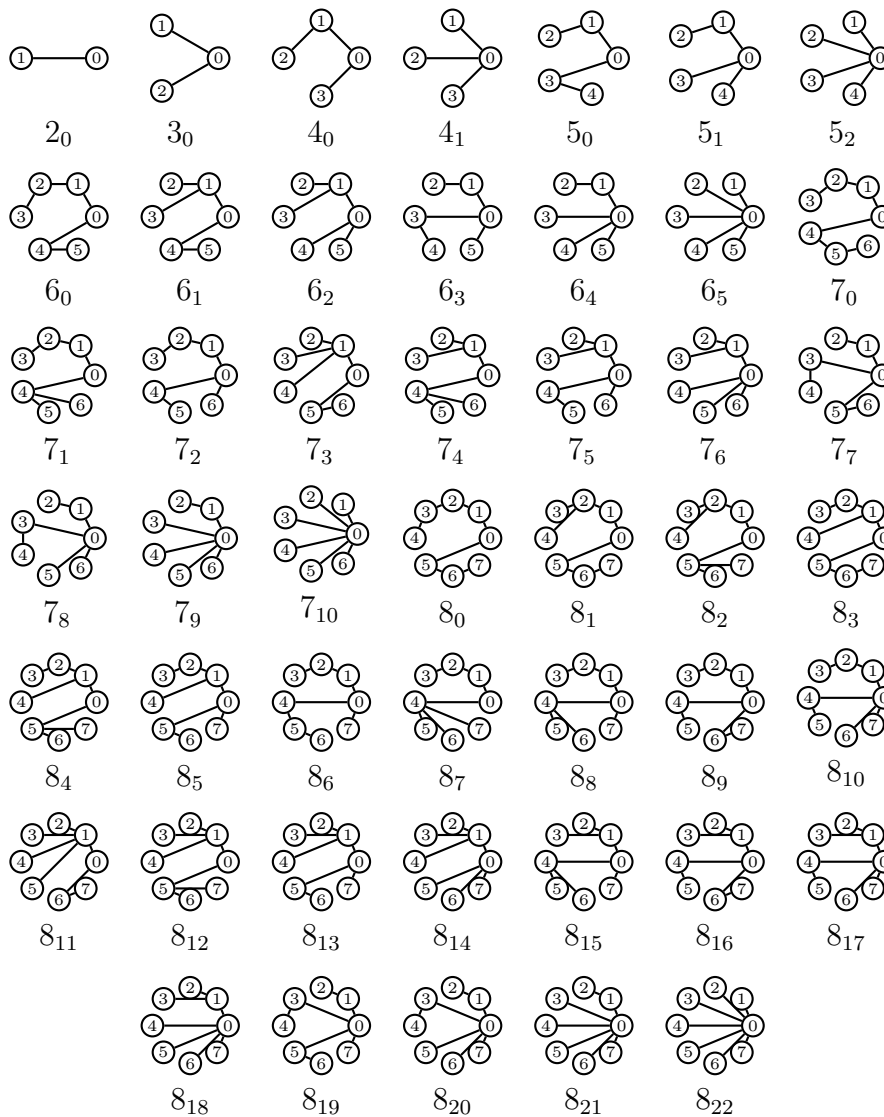

Figure 5.5: Trees with at most 8 vertices. The indexing is used in Tables 5.2 and 5.3 to associate vertices with entries of the configurations.

Among the critical configurations, the identity element is one of the most studied since it shows interesting patterns, see [66, Section 5.7]. In this section, we focus on the critical configurations associated with the identity element of the sandpile group of the dual graph of an outerplane graph where the vertex associated with the outer face is taken as sink.

Next result gives a method to compute the identity element.

Proposition 5.5.1. [66, Proposition 5.7.1] *Let G be a connected graph with sink vertex q . Let $\sigma_{max} \in \mathbb{N}^{V(G)}$ be the configuration in which the entry associated with vertex v equals $\deg_G(v) - 1$. The critical configuration obtained from the stabilization*

$$s(2\sigma_{max} - s(2\sigma_{max}))$$

is the identity element.

Given a tree T with n vertices and a vector $c \in \mathbb{N}^n$, whose entries are associated with the vertices of T , and c is such that $c_v \geq \deg_T(v)$ for any non-leaf vertex $v \in T$ and $c_v \geq 2$ whenever v is a leaf in T . Let $G_{T,c}$ be the planar graph obtained from T by adding a sink vertex q and adding $c_v - \deg_T(v)$ edges between the vertices v and q , for each $v \in V(T)$. Thus $c_v = \deg_{G_{T,c}}(v)$ for $v \in V(T)$. The graphs T and $G_{T,c}$ are the weak dual and dual of a family $F(T, c)$ of outerplane graphs. Note the graphs in this family have the same sandpile group.

In Figure 5.5, we give the trees with at most 8 vertices, the indexing on the vertices will be used to associate the entries of the configurations.

Example 5.5.2. *Consider graph 6_2 of Figure 5.5. The graph $G(6_2, (4, 5, 3, 3, 3, 3))$ is isomorphic to the dual graph of the plane graph G of Figure 5.2. Also, the graphs $G(6_2, (3, 3, 3, 3, 3, 3))$ and $G(6_2, (6, 5, 3, 3, 3, 3))$ are isomorphic to the dual graphs of the plane graphs G_1 and G_2 of Figure 5.3, respectively.*

In Tables 5.2 and 5.3 is given the identity element of the sandpile group of $G_{T,c}$ for selected values of c . The entry of the sink has been omitted in the critical configurations. For Table 5.2, the graph $G_{T,c}$ obtained in the first and second column can be regarded as if 1 and 2 edges were added between each leaf of T and the sink q , respectively. For Table 5.3, the graph $G_{T,c}$ obtained in the first and second column can be regarded as if 1 and 2 edges were added between each vertex of T and the sink q , respectively.

There are many patterns in the identity element, for example, in Table 5.2, we see that the identity element of $G_{T,c}$ when T is a star with at least 3 leaves and the leaves of T are the only vertices connected with the sink. Therefore, given configuration c , if c_v is 1 whenever the corresponding vertex is a leaf and 0 otherwise. Then c is the identity element. It is also interesting to see in Table 5.3 that when the outerplane graph satisfy that exactly one edge of each inner face is adjacent with the outer face, then the identity element of the sandpile group of the dual with the outer face vertex as sink is the $\mathbf{1}$ configuration. An analogous result is observed when 2 faces are shared. From which is conjectured that $G_{T,c}$ with $c = \deg(T) + k$, then the critical configuration is $k\mathbf{1}$.

T	c	identity	c	identity
20	[2, 2]	[1, 1]	[3, 3]	[2, 2]
30	[2, 2, 2]	[0, 1, 1]	[2, 3, 3]	[0, 2, 2]
40	[2, 2, 2, 2]	[1, 1, 1, 1]	[2, 2, 3, 3]	[1, 1, 1, 1]
41	[3, 2, 2, 2]	[0, 1, 1, 1]	[3, 3, 3, 3]	[0, 2, 2, 2]
50	[2, 2, 2, 2, 2]	[0, 1, 1, 1, 1]	[2, 2, 3, 2, 3]	[0, 1, 1, 1, 1]
51	[3, 2, 2, 2, 2]	[2, 1, 1, 1, 1]	[3, 2, 3, 3, 3]	[2, 1, 1, 1, 1]
52	[4, 2, 2, 2, 2]	[0, 1, 1, 1, 1]	[4, 3, 3, 3, 3]	[0, 2, 2, 2, 2]
60	[2, 2, 2, 2, 2, 2]	[1, 1, 1, 1, 1, 1]	[2, 2, 2, 3, 2, 3]	[1, 1, 1, 2, 1, 2]
61	[2, 3, 2, 2, 2, 2]	[0, 2, 1, 1, 1, 1]	[2, 3, 3, 3, 2, 3]	[0, 2, 1, 1, 1, 1]
62	[3, 3, 2, 2, 2, 2]	[2, 2, 1, 1, 1, 1]	[3, 3, 3, 3, 3, 3]	[2, 2, 1, 1, 1, 1]
63	[3, 2, 2, 2, 2, 2]	[1, 1, 1, 1, 1, 1]	[3, 2, 3, 2, 3, 3]	[1, 1, 1, 1, 1, 1]
64	[4, 2, 2, 2, 2, 2]	[3, 1, 1, 1, 1, 1]	[4, 2, 3, 3, 3, 3]	[3, 1, 1, 1, 1, 1]
65	[5, 2, 2, 2, 2, 2]	[0, 1, 1, 1, 1, 1]	[5, 3, 3, 3, 3, 3]	[0, 2, 2, 2, 2, 2]
70	[2, 2, 2, 2, 2, 2, 2]	[0, 1, 1, 1, 1, 1, 1]	[2, 2, 2, 3, 2, 2, 3]	[0, 1, 1, 2, 1, 1, 2]
71	[2, 2, 2, 2, 3, 2, 2]	[1, 1, 0, 1, 1, 1, 1]	[2, 2, 2, 3, 3, 3, 3]	[1, 1, 0, 1, 1, 1, 1]
72	[3, 2, 2, 2, 2, 2, 2]	[1, 0, 1, 1, 1, 1, 1]	[3, 2, 2, 3, 2, 3, 3]	[1, 0, 1, 1, 1, 1, 1]
73	[2, 4, 2, 2, 2, 2, 2]	[0, 3, 1, 1, 1, 1, 1]	[2, 4, 3, 3, 3, 2, 3]	[0, 3, 1, 1, 1, 1, 1]
74	[2, 3, 2, 2, 3, 2, 2]	[0, 2, 1, 1, 2, 1, 1]	[2, 3, 3, 3, 3, 3, 3]	[0, 2, 1, 1, 2, 1, 1]
75	[3, 3, 2, 2, 2, 2, 2]	[1, 2, 1, 1, 1, 1, 1]	[3, 3, 3, 3, 2, 3, 3]	[1, 2, 1, 1, 1, 1, 1]
76	[4, 3, 2, 2, 2, 2, 2]	[3, 2, 1, 1, 1, 1, 1]	[4, 3, 3, 3, 3, 3, 3]	[3, 2, 1, 1, 1, 1, 1]
77	[3, 2, 2, 2, 2, 2, 2]	[0, 1, 1, 1, 1, 1, 1]	[3, 2, 3, 2, 3, 2, 3]	[0, 1, 1, 1, 1, 1, 1]
78	[4, 2, 2, 2, 2, 2, 2]	[2, 1, 1, 1, 1, 1, 1]	[4, 2, 3, 2, 3, 3, 3]	[2, 1, 1, 1, 1, 1, 1]
79	[5, 2, 2, 2, 2, 2, 2]	[4, 1, 1, 1, 1, 1, 1]	[5, 2, 3, 3, 3, 3, 3]	[4, 1, 1, 1, 1, 1, 1]
710	[6, 2, 2, 2, 2, 2, 2]	[0, 1, 1, 1, 1, 1, 1]	[6, 3, 3, 3, 3, 3, 3]	[0, 2, 2, 2, 2, 2, 2]
80	[2, 2, 2, 2, 2, 2, 2, 2]	[1, 1, 1, 1, 1, 1, 1, 1]	[2, 2, 2, 2, 3, 2, 2, 3]	[1, 1, 1, 1, 1, 1, 1, 1]
81	[2, 2, 3, 2, 2, 2, 2, 2]	[1, 1, 0, 1, 1, 1, 1, 1]	[2, 2, 3, 3, 3, 2, 2, 3]	[1, 1, 0, 1, 1, 1, 1, 1]
82	[2, 2, 3, 2, 2, 3, 2, 2]	[1, 1, 1, 1, 1, 1, 1, 1]	[2, 2, 3, 3, 3, 3, 3, 3]	[1, 1, 1, 1, 1, 1, 1, 1]
83	[2, 3, 2, 2, 2, 2, 2, 2]	[1, 2, 1, 0, 1, 1, 1, 1]	[2, 3, 2, 3, 3, 2, 2, 3]	[1, 2, 1, 0, 2, 1, 1, 2]
84	[2, 3, 2, 2, 2, 3, 2, 2]	[0, 1, 1, 1, 1, 2, 1, 1]	[2, 3, 2, 3, 3, 3, 3, 3]	[0, 1, 1, 1, 1, 2, 1, 1]
85	[3, 3, 2, 2, 2, 2, 2, 2]	[1, 1, 1, 1, 1, 1, 1, 1]	[3, 3, 2, 3, 3, 2, 3, 3]	[1, 1, 1, 1, 1, 1, 1, 1]
86	[3, 2, 2, 2, 2, 2, 2, 2]	[2, 1, 1, 0, 1, 1, 0, 1]	[3, 2, 2, 3, 2, 2, 3, 3]	[2, 1, 1, 0, 1, 1, 0, 2]
87	[2, 2, 2, 2, 4, 2, 2, 2]	[1, 1, 0, 1, 2, 1, 1, 1]	[2, 2, 2, 3, 4, 3, 3, 3]	[1, 1, 0, 1, 2, 1, 1, 1]
88	[3, 2, 2, 2, 3, 2, 2, 2]	[1, 0, 1, 1, 2, 1, 1, 1]	[3, 2, 2, 3, 3, 3, 3, 3]	[1, 0, 1, 1, 2, 1, 1, 1]
89	[3, 2, 2, 2, 2, 2, 2, 2]	[2, 1, 1, 1, 1, 1, 1, 1]	[3, 2, 2, 3, 2, 3, 2, 3]	[2, 1, 1, 2, 1, 2, 1, 2]
810	[4, 2, 2, 2, 2, 2, 2, 2]	[2, 0, 1, 1, 1, 1, 1, 1]	[4, 2, 2, 3, 2, 3, 3, 3]	[2, 0, 1, 1, 1, 1, 1, 1]
811	[2, 5, 2, 2, 2, 2, 2, 2]	[0, 4, 1, 1, 1, 1, 1, 1]	[2, 5, 3, 3, 3, 3, 2, 3]	[0, 4, 1, 1, 1, 1, 1, 1]
812	[2, 4, 2, 2, 2, 3, 2, 2]	[0, 3, 1, 1, 1, 2, 1, 1]	[2, 4, 3, 3, 3, 3, 3, 3]	[0, 3, 1, 1, 1, 2, 1, 1]
813	[3, 4, 2, 2, 2, 2, 2, 2]	[1, 3, 1, 1, 1, 1, 1, 1]	[3, 4, 3, 3, 3, 2, 3, 3]	[1, 3, 1, 1, 1, 1, 1, 1]
814	[4, 4, 2, 2, 2, 2, 2, 2]	[3, 3, 1, 1, 1, 1, 1, 1]	[4, 4, 3, 3, 3, 3, 3, 3]	[3, 3, 1, 1, 1, 1, 1, 1]
815	[3, 3, 2, 2, 3, 2, 2, 2]	[1, 2, 1, 1, 2, 1, 1, 1]	[3, 3, 3, 3, 3, 3, 3, 3]	[1, 2, 1, 1, 2, 1, 1, 1]
816	[3, 3, 2, 2, 2, 2, 2, 2]	[0, 2, 1, 1, 1, 1, 1, 1]	[3, 3, 3, 3, 2, 3, 2, 3]	[0, 2, 1, 1, 1, 1, 1, 1]
817	[4, 3, 2, 2, 2, 2, 2, 2]	[2, 2, 1, 1, 1, 1, 1, 1]	[4, 3, 3, 3, 2, 3, 3, 3]	[2, 2, 1, 1, 1, 1, 1, 1]
818	[5, 3, 2, 2, 2, 2, 2, 2]	[4, 2, 1, 1, 1, 1, 1, 1]	[5, 3, 3, 3, 3, 3, 3, 3]	[4, 2, 1, 1, 1, 1, 1, 1]
819	[4, 2, 2, 2, 2, 2, 2, 2]	[1, 1, 1, 1, 1, 1, 1, 1]	[4, 2, 3, 2, 3, 2, 3, 3]	[1, 1, 1, 1, 1, 1, 1, 1]
820	[5, 2, 2, 2, 2, 2, 2, 2]	[3, 1, 1, 1, 1, 1, 1, 1]	[5, 2, 3, 2, 3, 3, 3, 3]	[3, 1, 1, 1, 1, 1, 1, 1]
821	[6, 2, 2, 2, 2, 2, 2, 2]	[5, 1, 1, 1, 1, 1, 1, 1]	[6, 2, 3, 3, 3, 3, 3, 3]	[5, 1, 1, 1, 1, 1, 1, 1]
822	[7, 2, 2, 2, 2, 2, 2, 2]	[0, 1, 1, 1, 1, 1, 1, 1]	[7, 3, 3, 3, 3, 3, 3, 3]	[0, 2, 2, 2, 2, 2, 2, 2]

Table 5.2: The identity element of the sandpile group of $G_{T,c}$.

It is known that if G is a planar graph and G^* is a dual graph of G , then $K(G) \cong K(G^*)$. And, there is an isomorphism between the critical configurations of $K(G)$ and the critical configurations of $K(G^*)$. In [44, Section 13.2], a method was given to recover the critical configuration of a dual graph from a critical configuration of plane graph. This method can be used to obtain the identity element of the sandpile group of the outerplane graphs whose dual is $G_{T,c}$. In the following the method is described.

Let H be a plane graph and H^* be the dual graph. Consider a planar drawing of H and H^* where each edge in $E(H)$ is crossed once by an edge in $E(H^*)$. This associate bijectively the edges of H with the edges of H^* . An *orientation* of a graph is a choice of direction of each edge of the graph, and thus one end of the edge is the *head* and the other end is the *tail*. Given an orientation of the edges of H , the *right-left rule* to orient the edges of H^* consists in, for each edge $e \in E(H)$, following the direction of e , the direction of the associated edge $e^* \in E(H^*)$ goes from the right face to the left face separated by e . Now, given a critical configuration d of the sandpile group $K(H)$ with sink q , take $d_q = -\sum_{v \in V(H) \setminus q} d_v$. Consider an orientation of H , and orient the edges of H^* following the right-left rule. Find an $f \in \mathbb{Z}^{E(H)}$ such that $\partial(H)f = d$, where $\partial(H)$ is the *oriented incidence matrix*. Take $f' \in \mathbb{Z}^{E(H^*)}$

T	c	identity	c	identity
20	[2, 2]	[1, 1]	[3, 3]	[2, 2]
30	[3, 2, 2]	[1, 1, 1]	[4, 3, 3]	[2, 2, 2]
40	[3, 3, 2, 2]	[1, 1, 1, 1]	[4, 4, 3, 3]	[2, 2, 2, 2]
41	[4, 2, 2, 2]	[1, 1, 1, 1]	[5, 3, 3, 3]	[2, 2, 2, 2]
50	[3, 3, 2, 3, 2]	[1, 1, 1, 1, 1]	[4, 4, 3, 4, 3]	[2, 2, 2, 2, 2]
51	[4, 3, 2, 2, 2]	[1, 1, 1, 1, 1]	[5, 4, 3, 3, 3]	[2, 2, 2, 2, 2]
52	[5, 2, 2, 2, 2]	[1, 1, 1, 1, 1]	[6, 3, 3, 3, 3]	[2, 2, 2, 2, 2]
60	[3, 3, 3, 2, 3, 2]	[1, 1, 1, 1, 1, 1]	[4, 4, 4, 3, 4, 3]	[2, 2, 2, 2, 2, 2]
61	[3, 4, 2, 2, 3, 2]	[1, 1, 1, 1, 1, 1]	[4, 5, 3, 3, 4, 3]	[2, 2, 2, 2, 2, 2]
62	[4, 4, 2, 2, 2, 2]	[1, 1, 1, 1, 1, 1]	[5, 5, 3, 3, 3, 3]	[2, 2, 2, 2, 2, 2]
63	[4, 3, 2, 3, 2, 2]	[1, 1, 1, 1, 1, 1]	[5, 4, 3, 4, 3, 3]	[2, 2, 2, 2, 2, 2]
64	[5, 3, 2, 2, 2, 2]	[1, 1, 1, 1, 1, 1]	[6, 4, 3, 3, 3, 3]	[2, 2, 2, 2, 2, 2]
65	[6, 2, 2, 2, 2, 2]	[1, 1, 1, 1, 1, 1]	[7, 3, 3, 3, 3, 3]	[2, 2, 2, 2, 2, 2]
70	[3, 3, 3, 2, 3, 3, 2]	[1, 1, 1, 1, 1, 1, 1]	[4, 4, 4, 3, 4, 4, 3]	[2, 2, 2, 2, 2, 2, 2]
71	[3, 3, 3, 2, 4, 2, 2]	[1, 1, 1, 1, 1, 1, 1]	[4, 4, 4, 3, 5, 3, 3]	[2, 2, 2, 2, 2, 2, 2]
72	[4, 3, 3, 2, 3, 2, 2]	[1, 1, 1, 1, 1, 1, 1]	[5, 4, 4, 3, 4, 3, 3]	[2, 2, 2, 2, 2, 2, 2]
73	[3, 5, 2, 2, 2, 3, 2]	[1, 1, 1, 1, 1, 1, 1]	[4, 6, 3, 3, 3, 4, 3]	[2, 2, 2, 2, 2, 2, 2]
74	[3, 4, 2, 2, 4, 2, 2]	[1, 1, 1, 1, 1, 1, 1]	[4, 5, 3, 3, 5, 3, 3]	[2, 2, 2, 2, 2, 2, 2]
75	[4, 4, 2, 2, 3, 2, 2]	[1, 1, 1, 1, 1, 1, 1]	[5, 5, 3, 3, 4, 3, 3]	[2, 2, 2, 2, 2, 2, 2]
76	[5, 4, 2, 2, 2, 2, 2]	[1, 1, 1, 1, 1, 1, 1]	[6, 5, 3, 3, 3, 3, 3]	[2, 2, 2, 2, 2, 2, 2]
77	[4, 3, 2, 3, 2, 3, 2]	[1, 1, 1, 1, 1, 1, 1]	[5, 4, 3, 4, 3, 4, 3]	[2, 2, 2, 2, 2, 2, 2]
78	[5, 3, 2, 3, 2, 2, 2]	[1, 1, 1, 1, 1, 1, 1]	[6, 4, 3, 4, 3, 3, 3]	[2, 2, 2, 2, 2, 2, 2]
79	[6, 3, 2, 2, 2, 2, 2]	[1, 1, 1, 1, 1, 1, 1]	[7, 4, 3, 3, 3, 3, 3]	[2, 2, 2, 2, 2, 2, 2]
710	[7, 2, 2, 2, 2, 2, 2]	[1, 1, 1, 1, 1, 1, 1]	[8, 3, 3, 3, 3, 3, 3]	[2, 2, 2, 2, 2, 2, 2]
80	[3, 3, 3, 3, 2, 3, 3, 2]	[1, 1, 1, 1, 1, 1, 1, 1]	[4, 4, 4, 4, 3, 4, 4, 3]	[2, 2, 2, 2, 2, 2, 2, 2]
81	[3, 3, 4, 2, 2, 3, 3, 2]	[1, 1, 1, 1, 1, 1, 1, 1]	[4, 4, 5, 3, 3, 4, 4, 3]	[2, 2, 2, 2, 2, 2, 2, 2]
82	[3, 3, 4, 2, 2, 4, 2, 2]	[1, 1, 1, 1, 1, 1, 1, 1]	[4, 4, 5, 3, 3, 5, 3, 3]	[2, 2, 2, 2, 2, 2, 2, 2]
83	[3, 4, 3, 2, 2, 3, 3, 2]	[1, 1, 1, 1, 1, 1, 1, 1]	[4, 5, 4, 3, 3, 4, 4, 3]	[2, 2, 2, 2, 2, 2, 2, 2]
84	[3, 4, 3, 2, 2, 4, 2, 2]	[1, 1, 1, 1, 1, 1, 1, 1]	[4, 5, 4, 3, 3, 5, 3, 3]	[2, 2, 2, 2, 2, 2, 2, 2]
85	[4, 4, 3, 2, 2, 3, 2, 2]	[1, 1, 1, 1, 1, 1, 1, 1]	[5, 5, 4, 3, 3, 4, 3, 3]	[2, 2, 2, 2, 2, 2, 2, 2]
86	[4, 3, 3, 2, 3, 3, 2, 2]	[1, 1, 1, 1, 1, 1, 1, 1]	[5, 4, 4, 3, 4, 4, 3, 3]	[2, 2, 2, 2, 2, 2, 2, 2]
87	[3, 3, 3, 2, 5, 2, 2, 2]	[1, 1, 1, 1, 1, 1, 1, 1]	[4, 4, 4, 3, 6, 3, 3, 3]	[2, 2, 2, 2, 2, 2, 2, 2]
88	[4, 3, 3, 2, 4, 2, 2, 2]	[1, 1, 1, 1, 1, 1, 1, 1]	[5, 4, 4, 3, 5, 3, 3, 3]	[2, 2, 2, 2, 2, 2, 2, 2]
89	[4, 3, 3, 2, 3, 2, 3, 2]	[1, 1, 1, 1, 1, 1, 1, 1]	[5, 4, 4, 3, 4, 3, 4, 3]	[2, 2, 2, 2, 2, 2, 2, 2]
810	[5, 3, 3, 2, 3, 2, 2, 2]	[1, 1, 1, 1, 1, 1, 1, 1]	[6, 4, 4, 3, 4, 3, 3, 3]	[2, 2, 2, 2, 2, 2, 2, 2]
811	[3, 6, 2, 2, 2, 2, 3, 2]	[1, 1, 1, 1, 1, 1, 1, 1]	[4, 7, 3, 3, 3, 3, 4, 3]	[2, 2, 2, 2, 2, 2, 2, 2]
812	[3, 5, 2, 2, 2, 4, 2, 2]	[1, 1, 1, 1, 1, 1, 1, 1]	[4, 6, 3, 3, 3, 5, 3, 3]	[2, 2, 2, 2, 2, 2, 2, 2]
813	[4, 5, 2, 2, 2, 3, 2, 2]	[1, 1, 1, 1, 1, 1, 1, 1]	[5, 6, 3, 3, 3, 4, 3, 3]	[2, 2, 2, 2, 2, 2, 2, 2]
814	[5, 5, 2, 2, 2, 2, 2, 2]	[1, 1, 1, 1, 1, 1, 1, 1]	[6, 6, 3, 3, 3, 3, 3, 3]	[2, 2, 2, 2, 2, 2, 2, 2]
815	[4, 4, 2, 2, 4, 2, 2, 2]	[1, 1, 1, 1, 1, 1, 1, 1]	[5, 5, 3, 3, 5, 3, 3, 3]	[2, 2, 2, 2, 2, 2, 2, 2]
816	[4, 4, 2, 2, 3, 2, 3, 2]	[1, 1, 1, 1, 1, 1, 1, 1]	[5, 5, 3, 3, 4, 3, 4, 3]	[2, 2, 2, 2, 2, 2, 2, 2]
817	[5, 4, 2, 2, 3, 2, 2, 2]	[1, 1, 1, 1, 1, 1, 1, 1]	[6, 5, 3, 3, 4, 3, 3, 3]	[2, 2, 2, 2, 2, 2, 2, 2]
818	[6, 4, 2, 2, 2, 2, 2, 2]	[1, 1, 1, 1, 1, 1, 1, 1]	[7, 5, 3, 3, 3, 3, 3, 3]	[2, 2, 2, 2, 2, 2, 2, 2]
819	[5, 3, 2, 3, 2, 3, 2, 2]	[1, 1, 1, 1, 1, 1, 1, 1]	[6, 4, 3, 4, 3, 4, 3, 3]	[2, 2, 2, 2, 2, 2, 2, 2]
820	[6, 3, 2, 3, 2, 2, 2, 2]	[1, 1, 1, 1, 1, 1, 1, 1]	[7, 4, 3, 4, 3, 3, 3, 3]	[2, 2, 2, 2, 2, 2, 2, 2]
821	[7, 3, 2, 2, 2, 2, 2, 2]	[1, 1, 1, 1, 1, 1, 1, 1]	[8, 4, 3, 3, 3, 3, 3, 3]	[2, 2, 2, 2, 2, 2, 2, 2]
822	[8, 2, 2, 2, 2, 2, 2, 2]	[1, 1, 1, 1, 1, 1, 1, 1]	[9, 3, 3, 3, 3, 3, 3, 3]	[2, 2, 2, 2, 2, 2, 2, 2]

Table 5.3: The identity element of the sandpile group of $G_{T,c}$.

such that $f'_{e^*} = f_e$. The configuration $d' = \partial(H^*)f'$ is in the equivalence class of the critical configuration in $K(H^*)$ we are looking for. To find the critical configuration in the class of d' , we suggest to use the following result.

Proposition 5.5.3. [12, Theorem 2.4] *Let G be a graph with sink vertex q , and $c \in \mathbb{Z}^{V(G)\setminus q}$. If x^* is an optimal solution of the integer linear program*

$$\begin{aligned}
 & \text{maximize} && \mathbf{1} \cdot x \\
 & \text{subject to} && \mathbf{0} \leq c + xL_q(G) \leq \sigma_{max}, \\
 & && x \in \mathbb{Z}^{V(G)\setminus q},
 \end{aligned}$$

then x^ is unique and $c + x^*L_q(G)$ is a critical configuration in $SP(G, q)$ in the equivalence class of c .*

Let us see an example of the procedure to obtain a critical configuration in $K(H^*)$ given a configuration in $K(H)$.

Example 5.5.4. *Let H and H^* be the black and blue plane graphs shown in Figure 5.6.a, together with the indexing of the non-sink vertices. Where the vertices q*

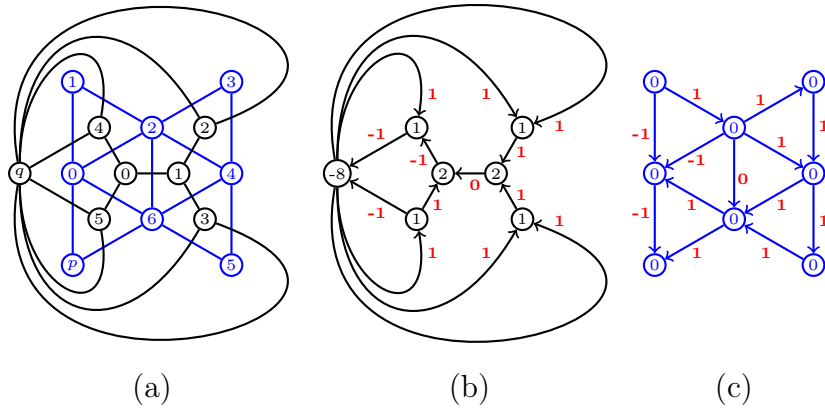

Figure 5.6: Computation of a configuration in H^* associated with the critical configuration in H .

and p are the sink vertices in H and H^* . Note H is isomorphic to the graph $G_{T,c}$ where T is the tree 6_2 in Figure 5.5 and c satisfy that the sink is adjacent only with the leaves by exactly 2 edges. Following the indices described in Figure 5.6.a, the configuration $d = (2, 2, 1, 1, 1, 1, -8)$ is the identity element of $K(H)$ up to the value of the sink q . Given the orientation of H described in Figure 5.6.b, the oriented incidence matrix $\partial(H)$ of H is the following:

$$\begin{matrix} & 04 & 10 & 21 & 31 & 4q & 50 & 5q & q2 & q2' & q3 & q3' & q4 & q5 \\ \begin{matrix} 0 \\ 1 \\ 2 \\ 3 \\ 4 \\ 5 \\ q \end{matrix} & \begin{pmatrix} -1 & 1 & 0 & 0 & 0 & 1 & 0 & 0 & 0 & 0 & 0 & 0 & 0 & 0 \\ 0 & -1 & 1 & 1 & 0 & 0 & 0 & 0 & 0 & 0 & 0 & 0 & 0 & 0 \\ 0 & 0 & -1 & 0 & 0 & 0 & 0 & 0 & 1 & 1 & 0 & 0 & 0 & 0 \\ 0 & 0 & 0 & -1 & 0 & 0 & 0 & 0 & 0 & 0 & 1 & 1 & 0 & 0 \\ 1 & 0 & 0 & 0 & -1 & 0 & 0 & 0 & 0 & 0 & 0 & 0 & 1 & 0 \\ 0 & 0 & 0 & 0 & 0 & -1 & -1 & 0 & 0 & 0 & 0 & 0 & 0 & 1 \\ 0 & 0 & 0 & 0 & 1 & 0 & 1 & -1 & -1 & -1 & -1 & -1 & -1 & -1 \end{pmatrix} \end{matrix}.$$

Let $f = (-1, 0, 1, 1, -1, 1, -1, 1, 1, 1, 1, 1, 1, 1)$, which is shown in Figure 5.6.b. It can be seen that f satisfies that $\partial(H)f = d$. By using the right-left rule, we obtain the orientation of H^* shown in Figure 5.6.c. Thus, the oriented incidence matrix $\partial(H^*)$ is

$$\begin{matrix} & 0p & 10 & 12 & 20 & 23 & 24 & 26 & 34 & 45 & 46 & 56 & 60 & 6p \\ \begin{matrix} 0 \\ 1 \\ 2 \\ 3 \\ 4 \\ 5 \\ 6 \\ p \end{matrix} & \begin{pmatrix} -1 & 1 & 0 & 1 & 0 & 0 & 0 & 0 & 0 & 0 & 0 & 0 & 1 & 0 \\ 0 & -1 & -1 & 0 & 0 & 0 & 0 & 0 & 0 & 0 & 0 & 0 & 0 & 0 \\ 0 & 0 & 1 & -1 & -1 & -1 & -1 & 0 & 0 & 0 & 0 & 0 & 0 & 0 \\ 0 & 0 & 0 & 0 & 1 & 0 & 0 & -1 & 0 & 0 & 0 & 0 & 0 & 0 \\ 0 & 0 & 0 & 0 & 0 & 1 & 0 & 1 & -1 & -1 & 0 & 0 & 0 & 0 \\ 0 & 0 & 0 & 0 & 0 & 0 & 0 & 0 & 1 & 0 & -1 & 0 & 0 & 0 \\ 0 & 0 & 0 & 0 & 0 & 0 & 1 & 0 & 0 & 1 & 1 & -1 & -1 & 0 \\ 1 & 0 & 0 & 0 & 0 & 0 & 0 & 0 & 0 & 0 & 0 & 0 & 0 & 1 \end{pmatrix} \end{matrix}.$$

Dualizing f , we get $f' = (-1, -1, 1, -1, 1, 1, 0, 1, 1, 1, 1, 1, 1, 1)$, shown in Figure 5.6.c. From which we get the configuration $\partial(H^*)f' = (0, 0, 0, 0, 0, 0, 0, 0, 0, 0, 0, 0, 0, 0)$. Now, applying

Proposition 5.5.3, we get the following linear integer model:

$$\begin{array}{ll}
 \text{maximize} & \sum_{i=0}^6 x_i \\
 \text{subject to} & 0 \leq 4x_0 - x_1 - x_2 - x_6 \leq 3 \\
 & 0 \leq -x_0 + 2x_1 - x_2 \leq 1 \\
 & 0 \leq -x_0 - x_1 + 5x_2 - x_3 - x_4 - x_6 \leq 4 \\
 & 0 \leq -x_2 + 2x_3 - x_4 \leq 1 \\
 & 0 \leq -x_2 - x_3 + 4x_4 - x_5 - x_6 \leq 3 \\
 & 0 \leq -x_4 + 2x_5 - x_6 \leq 1 \\
 & 0 \leq -x_0 - x_2 - x_4 - x_5 + 5x_6 \leq 4 \\
 & x_i \in \mathbb{Z} \text{ for each } i \in \{0, \dots, 6\},
 \end{array}$$

whose optimal solution is $x^* = (5, 6, 7, 7, 7, 7, 6)$ and the critical configuration is $(1, 0, 4, 0, 1, 1, 4, p)$, which in fact is the identity element of the sandpile group of the outerplane graph H^* .

Graphs with few characteristic ideals

In this chapter we show an application of determinantal ideals of graph to the problem of the characterization of $\mathcal{K}_{\leq k}$. We use the characteristic ideals to find the family of regular graphs in $\mathcal{K}_{\leq 3}$. We do this by characterizing the graphs with at most three trivial characteristic ideals. We also show an alternative and simpler way to obtain the characterization of $\mathcal{S}_{\leq 3}$. Moreover, we present a list of 43 minimal forbidden graphs for $\mathcal{S}_{\leq 4}$.

Let us recall that the cokernel of the adjacency matrix $A(G)$ is known as the *Smith group* of G and is denoted $S(G)$, and the torsion part of the cokernel of the Laplacian matrix $L(G)$ is known as the *sandpile group* $K(G)$ of G . Smith groups were introduced in [84]. Recently, the computation of the Smith group for several families of graphs has attracted attention, see [20, 32, 48, 49, 95]. The sandpile group is especially interesting for connected graphs, since its order is equal to the number of spanning trees of the graph. The computation of the Smith normal form (SNF) of a matrix is a standard technique to determine its cokernel. Let us recall that the cokernel of M can be described as: $\text{coker}(M) \cong \mathbb{Z}_{d_1} \oplus \mathbb{Z}_{d_2} \oplus \cdots \oplus \mathbb{Z}_{d_r} \oplus \mathbb{Z}^{n-r}$, where d_1, d_2, \dots, d_r are positive integers with $d_i \mid d_j$ for all $i \leq j$. These integers are called *invariant factors* of M .

Let $\delta_1(M)$ denote the number of invariant factors of M equal to 1 and let us recall that $\delta_1(G) = \delta_1(L(G))$. The computation of the invariant factors of the Laplacian matrix is an important technique used in the understanding of the sandpile group. For instance, several researchers have addressed the question of how often the sandpile group is cyclic, that is, how often $\delta_1(G)$ is equal to $n - 2$? In [73] and [93] D. Lorenzini and D. Wagner, based on numerical data, suggest we could expect to find a substantial proportion of graphs having a cyclic sandpile group. Based on this, D. Wagner [93] conjectured that almost every connected simple graph has a cyclic sandpile group. A recent study [96] concluded that the probability that the sandpile group of a random graph is cyclic is asymptotically at most ≈ 0.7935212 ; differing from Wagner's conjecture. Besides, it is interesting [34] that for any given connected simple graph, there is a homeomorphic graph with cyclic sandpile group. The reader interested on this topic may consult [37, 73, 96] for more questions and results.

The characterization of the family \mathcal{K}_k of simple connected graphs having sandpile

group with k trivial invariant factors has been of great interest. Probably, it was initially posed by R. Cori¹. However, the first result appeared when D. Lorenzini noticed in [72], and independently A. Vince in [92], that the graphs in \mathcal{K}_1 consist only of complete graphs. After, C. Merino in [75] posed interest on the characterization of \mathcal{K}_2 and \mathcal{K}_3 . In this sense, some advances have been done. For instance, in [79] it was characterized the graphs in \mathcal{K}_2 whose third invariant factor is equal to n , $n - 1$, $n - 2$, or $n - 3$. In [59] the characterizations of the graphs in \mathcal{K}_2 with a cut vertex and number of independent cycles equal to $n - 2$ are given.

Later, a complete characterization of \mathcal{K}_2 was obtained in [10]. On the other hand, the characterization of the graphs in \mathcal{K}_3 seems to be a hard open problem [11]. For the case of digraphs, the characterization of digraphs with at most 1 invariant factor equal to 1 was completely obtained in [13]. These characterizations were obtained by using the *critical ideals* of a graph G , that are determinantal ideals, defined in [40], of the matrix $\text{Diag}(x_1, \dots, x_n) - A(G)$, where x_1, \dots, x_n are indeterminates. These ideals turned out to be related with other parameters like the *minimum rank* and the *zero-forcing number*, see [7]. Similar ideals for the distance and distance Laplacian matrices were introduced in [8] with the name of *distance ideals*. Therefore, for example, the family of graphs with 2 trivial distance ideals contains the family of graphs whose distance matrix has at most 2 invariant factors equal to 1. It is interesting that there is an infinite number of minimal forbidden graphs for the graphs with two trivial distance ideals, see [4].

In the context of the Smith groups of graphs, it would be also interesting to characterize graphs having Smith group with at most k invariant factors equal to 1. For this we introduce further notation, let $\mathcal{S}_{\leq k}$ denote the family of simple connected graphs whose adjacency matrix has at most k invariant factors equal to 1, that is, $\delta_1(A(G)) \leq k$. The characterization of the $\mathcal{S}_{\leq 1}$ and $\mathcal{S}_{\leq 2}$ can be derived from [10], and the characterization of the digraphs with $\delta_1(A(G)) \leq 1$ was obtained in [13]. However, nothing was known on the structure of $\mathcal{S}_{\leq k}$, for $k \geq 3$.

In Section 6.1, we introduce the concept of characteristic ideals which are determinantal ideals defined in [40] as a generalization of the sandpile (critical) group and the characteristic polynomial. Also, we present the characterization of the graphs with one and two trivial characteristic ideals, and by product the characterization of the regular graphs in $\mathcal{K}_{\leq 1}$ and $\mathcal{K}_{\leq 2}$. We show, in Section 6.2, the characterization of graphs with 3 trivial characteristic ideals, consequently, this is used to give a complete characterization of regular graphs in $\mathcal{K}_{\leq 3}$. The characterization of $\mathcal{S}_{\leq 1}$, $\mathcal{S}_{\leq 2}$, and $\mathcal{S}_{\leq 3}$ can be derived from the obtained results, however, in Section 6.3, we show an alternative and simpler way to characterize these graph families. We also present a list of 43 forbidden graphs for $\mathcal{S}_{\leq 4}$.

¹Personal communication with C. Merino

6.1. Characteristic ideals of graphs

Some properties of determinantal ideals of graphs can be found in [2]. For example, determinantal ideals of M satisfy

$$\langle 1 \rangle \supseteq I_1(M) \supseteq \cdots \supseteq I_n(M) \supseteq \langle 0 \rangle. \quad (6.1)$$

We recall the definition of characteristic ideals of graphs.

Definition 6.1.1. *The k -th characteristic ideal $A_k(G, t)$ of a graph G is the k -th determinantal ideal of the matrix $tI_n - A(G)$, that is, the ideal $\langle \text{minors}_k(tI_n - A(G)) \rangle \subseteq \mathbb{Z}[t]$.*

Definition 6.1.2. *The algebraic co-rank $\gamma_A(G)$ of a graph G is the maximum integer k such that $A_k(G, t)$ is trivial. Moreover, let $\mathcal{C}_{\leq k}$ denote the set of graphs H such that $\gamma_A(H) \leq k$.*

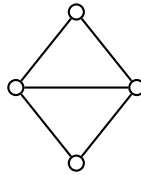

Figure 6.1: diamond graph

Computing Gröbner basis of a characteristic ideal are an useful computational tool to find a minimal generating set. They can be computed in SAGE with the following code.

```

1 # G is a graph
2 def CharIdeals(G):
3     n = G.order()
4     R = macaulay2.ring("ZZ", '[t,x]').to_sage()
5     R.inject_variables(verbose=False);
6     L = diagonal_matrix([t for i in xrange(n)]) - G.adjacency_matrix()
7     Gamma = 0
8     for i in range(n+1):
9         M = L.minors(i)
10        I = R.ideal(M).groebner_basis()
11        print("Groebner basis of char ideal of size " + str(i))
12        print(str(I))
13        if I[0] == 1:
14            Gamma = i
15    print("gamma_A = " + str(Gamma))

```

Example 6.1.3. *Retaking the diamond graph example. The Gröbner basis of the characteristic ideals and the algebraic co-rank of the diamond graph can be computed with the following SAGE code:*

```
1 CharIdeals(Graph("C^"))
```

Let us recall that the output is shown in Example 2.6.7

The connection of the characteristic ideals with the cokernel of the adjacency and Laplacian matrices is that the invariant factors can be recovered by evaluating the characteristic ideals. This rely on the Theorem of elementary divisors, details can be found in [62, Theorem 3.9].

Theorem 6.1.4 (Theorem of elementary divisors). *Let M a integer matrix of rank r with d_1, \dots, d_r its invariant factors. For $k \geq 1$, let Δ_k be the gcd of the k -minors of M , and $\Delta_0 = 1$. Then*

$$d_k = \frac{\Delta_k}{\Delta_{k-1}}.$$

Proposition 6.1.5. [2, Corollary 15] *For $k \in [n]$,*

$$A_k(G, 0) = \left\langle \prod_{j=1}^k d_j(A(G)) \right\rangle = \langle \Delta_k(A(G)) \rangle,$$

and if G is r -regular, then

$$A_k(G, r) = \left\langle \prod_{j=1}^k d_j(L(G)) \right\rangle = \langle \Delta_k(L(G)) \rangle,$$

where $\Delta_k(M)$ is the greatest common divisor of the k -minors of matrix M , and if $d_1(M) \mid \dots \mid d_r(M)$ are the invariant factors in the Smith normal form of M , then $d_k(M) = \frac{\Delta_k(M)}{\Delta_{k-1}(M)}$ with $\Delta_0(M) = 1$.

Example 6.1.6. *Continuing with the diamond graph. By evaluating, t at 0 in each characteristic ideal, we obtain that its SNF of the adjacency matrix is $\text{Diag}(1, 1, 2, 0)$, meanwhile, for this case the SNF of its Laplacian matrix cannot be obtained since the diamond graph is not regular.*

As consequence, if $A_k(G, t)$ is trivial, then the k -th invariant factor $d_k(A(G)) = 1$, and thus, $\gamma_A(G) \leq \delta_1(A(G))$. For the Laplacian matrix, we have the same when G is regular, that is, if G is regular, then $\gamma_A(G) \leq \delta_1(L(G))$. Then, the graphs in $\mathcal{S}_{\leq k}$ and the regular graphs in $\mathcal{K}_{\leq k}$ are contained in the family $\mathcal{C}_{\leq k}$ of graphs with at most k trivial characteristic ideals. By characterizing the graphs in $\mathcal{C}_{\leq k}$, we can use the containment to give a characterization of the regular graphs in $\mathcal{K}_{\leq k}$. Analogous ideas can be used to characterize $\mathcal{S}_{\leq k}$, however simpler ideas can be applied to obtain them, we will explore them in Section 6.3.

One advantage of characteristic ideals over sandpile groups is that characteristic ideals are monotone on induced subgraphs.

Lemma 6.1.7. *If H is an induced subgraph of G , then $A_k(H, t) \subseteq A_k(G, t)$.*

Proof. It follows since any k -minor of $tI_n - A(H)$ is also a k -minors of $tI_n - A(G)$. Therefore $\text{minors}_k(tI_n - A(H)) \subseteq \text{minors}_k(tI_n - A(G))$. \square

A similar result is not always true for the sandpile group, in fact, there are examples of graphs having different sandpile group, for instance, $K(K_4) \not\cong K(K_5)$. This is because, in general, it is not true that if H is an induced subgraph of G , then $L(H)$ is a submatrix of $L(G)$.

A graph G is *forbidden* for $\mathcal{C}_{\leq k}$ if $\gamma_A(G) \geq k + 1$. Thus, we can look for the minimal forbidden graphs to characterize the family $\mathcal{C}_{\leq k}$.

Lemma 6.1.8. *The path P_k with k vertices is forbidden for $\mathcal{C}_{\leq k-2}$.*

The following theorem give us the characterization of $\mathcal{C}_{\leq 1}$ and since the graphs in $\mathcal{K}_{\leq 1}$ are regular, we have $\mathcal{C}_{\leq 1} = \mathcal{K}_{\leq 1}$. Its proof is similar to Theorem 3.3 and Corollary 3.4 of [10].

Theorem 6.1.9. *Let G be connected simple graph. Then the following statements are equivalent.*

1. $G \in \mathcal{C}_{\leq 1}$,
2. $G \in \mathcal{K}_{\leq 1}$
3. G is P_3 -free
4. G is a complete graph

Now, before to give the characterizations of the graphs in $\mathcal{C}_{\leq 2}$, we show an explicit formula of the characteristic ideals of complete graphs and complete multipartite graphs.

Lemma 6.1.10. [40, Proposition 3.15 & Theorem 3.16] *Let G be a complete graph with n vertices. Then*

$$A_j(G, t) = \begin{cases} \langle (t+1)^{j-1} \rangle & 1 \leq j \leq n-1, \\ \langle (t-n+1)(t+1)^{n-1} \rangle & j = n. \end{cases}$$

Lemma 6.1.11. [53, Theorem 3.2] *Let G be a complete multipartite graph with $m \geq 2$ parts of size $r_1, \dots, r_m \geq 2$. Let $n = \sum r_i$. Then*

$$A_j(G, t) = \begin{cases} \langle 1 \rangle & j \leq m-1, \\ \langle (m-1)t^{j-m}, t^{j-m+1} \rangle & m \leq j \leq n-m, \\ \langle t^{j-m+1} \prod_{a=1}^{m-n+j-1} (t+r_{i_a}), P \rangle & n-m < j < n \\ \langle \sum_{a=0}^m e_a(r_1, \dots, r_m) t^{n-a} \rangle & j = n, \end{cases}$$

where P is equal to $\left\{ \sum_{a=0}^{m-k} (k-1+a)e_a(r_{i_1}, \dots, r_{i_{m-k}})t^{j-k-a} : k = n-j \geq 1 \text{ and } 1 \leq i_1 < \dots < i_{m-k} \leq m \right\}$, and $e_a(s_1, \dots, s_l)$ is the elementary symmetric polynomial of degree a in l variables, i.e.,

$$e_a(s_1, \dots, s_l) = \sum_{1 \leq s_{i_1} < \dots < s_{i_a} \leq l} s_{i_1} \cdots s_{i_a}.$$

Now, let us mention a couple of structural results needed for the characterization. The paw graph is shown in Figure 6.6.

Lemma 6.1.12. [78, Theorem 1] *Let G be a paw-free connected graph. Then G is either K_3 -free or complete multipartite graph.*

Lemma 6.1.13. [21, Proposition 1] *Let G be a $\{P_4, K_3\}$ -free connected graph, then G is a complete bipartite graph.*

Theorem 6.1.14. *Let G be connected simple graph. Then the following statements are equivalent:*

1. $G \in \mathcal{C}_{\leq 2}$,
2. G is $\{P_4, \text{paw}, K_5 - e\}$ -free,
3. G is complete graph or G is an induced subgraph of a complete tripartite graph.

Proof. (1) \implies (2) By Lemma 6.1.8, P_4 is forbidden for $\mathcal{C}_{\leq 2}$. Now considering

$$M = tI_4 - A(\text{paw}) = \begin{bmatrix} t & -1 & 0 & 0 \\ -1 & t & -1 & -1 \\ 0 & -1 & t & -1 \\ 0 & -1 & -1 & t \end{bmatrix},$$

we can obtain that $A_1(\text{paw}, t)$ and $A_2(\text{paw}, t)$ are trivial since there are appropriate minors of M equal to 1. Let

$$p(t) = \det(M[\{1, 2, 3\}; \{1, 2, 4\}]) = -t^2 - t + 1$$

and

$$q(t) = \det(M[\{1, 2, 3\}; \{1, 3, 4\}]) = t^2 + t.$$

Since $1 = p(t) + q(t) \in A_3(\text{paw}, t)$, then $A_3(\text{paw}, t)$ is trivial. Thus paw is forbidden for $\mathcal{C}_{\leq 2}$. Now, let

$$M = tI_5 - A(K_5 - e) = \begin{bmatrix} t & 0 & -1 & -1 & -1 \\ 0 & t & -1 & -1 & -1 \\ -1 & -1 & t & -1 & -1 \\ -1 & -1 & -1 & t & -1 \\ -1 & -1 & -1 & -1 & t \end{bmatrix}.$$

And, let

$$p(t) = \det(M[\{1, 2, 3\}; \{1, 2, 4\}]) = -t^2 - 2t$$

and

$$q(t) = \det(M[\{2, 3, 4\}; \{2, 3, 5\}]) = -t^2 - 2t - 1.$$

Since $1 = p(t) - q(t)$, then $A_3(K_5 - e, t)$ is trivial. From which follows that $K_5 - e$ is forbidden for $\mathcal{C}_{\leq 2}$.

(2) \implies (3) By Lemma 6.1.12, a **paw**-free graph is either K_3 or a complete multipartite graph. In the first case, considering that G is also P_4 -free, then by Lemma 6.1.13, G is a bipartite graph. On the other hand, let G be a complete multipartite graph with more than 3 partite sets. Since G is $\{K_5 - e\}$ -free, then each partite set has at most one vertex, that is, G is a complete graph.

(3) \implies (1) Lemma 6.1.10 states complete graphs have at most one trivial characteristic ideal. Now let G be a complete tripartite graph with each part of size at least 2. By Lemma 6.1.11, we have the third characteristic ideal is not trivial. Thus by Lemma 6.1.7, if H is an induced subgraph of G , then H has at most 2 trivial characteristic ideals. \square

The characterization of the regular graphs whose sandpile group have 2 trivial invariant factors follows by evaluating the third characteristic ideal of these graphs at t equal the degree of any vertex.

Corollary 6.1.15. *Let G be a connected simple regular graph. Then $G \in \mathcal{K}_{\leq 2}$ if and only if G is either a complete graph K_r , a regular complete bipartite graph $K_{r,r}$ or a regular complete tripartite graph $K_{r,r,r}$.*

Proof. Since G is regular and $G \in \mathcal{C}_{\leq 2}$, then G is either a complete graph K_r , a regular complete bipartite graph $K_{r,r}$ or a regular complete tripartite graph $K_{r,r,r}$. On the other hand, let G be any of these graphs. By Lemmas 6.1.10 and 6.1.11, the third characteristic ideal of G is

$$A_3(G, t) = \begin{cases} \langle (t+1)^2(t-2) \rangle & K_{r+1} \text{ with } r = 2, \\ \langle (t+1)^2 \rangle & K_{r+1} \text{ with } r \geq 3, \\ \langle t^2, 2t \rangle & K_{r,r} \text{ with } r = 2, \\ \langle t \rangle & K_{r,r} \text{ with } r \geq 3, \\ \langle 2, t \rangle & K_{r,r,r} \text{ with } r \geq 2. \end{cases}$$

By evaluating $A_2(G, t)$ and $A_3(G, t)$ at t equal the degree of any vertex of G , we obtain that the third invariant factor of G is different than 1. \square

A characterization of the graphs with Smith groups having two trivial invariant factors can also be obtained by evaluating the third characteristic ideal of a complete graph or and induced subgraph of a tripartite graph at $t = 0$, however, we will use simpler ideas in Section 6.3.

6.2. Regular graphs with at most 3 trivial characteristic ideals

In this section we will characterize the graphs with at most 3 trivial characteristic ideals. As consequence, we will obtain a complete characterization of the regular graphs in $\mathcal{K}_{\leq 3}$.

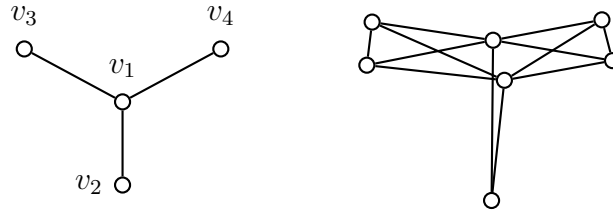

Figure 6.2: S_4 and $S_4^{\mathbf{r}}$ with $\mathbf{r} = (2, 1, -2, -2)$

Given a graph $G = (V, E)$ and a vector $\mathbf{d} \in \mathbb{Z}^V$, the graph $G^{\mathbf{d}}$ is constructed as follows. For each vertex $u \in V$, associate a new vertex set V_u , where V_u is a clique of cardinality $-\mathbf{d}_u$ when \mathbf{d}_u is negative, and V_u is a stable set of cardinality \mathbf{d}_u if \mathbf{d}_u when positive. Each vertex in V_u is adjacent with each vertex in V_v if and only if u and v are adjacent in G . Then the graph G is called the *underlying graph* of $G^{\mathbf{d}}$. For instance, let S_n denote the star graph with n vertices; with one apex vertex and $n - 1$ leaves. In Figure 6.2 there is a drawing of S_4 and $S_4^{\mathbf{r}}$ with $\mathbf{r} = (2, 1, -2, -2)$, where the first entry of \mathbf{r} is associated with the apex vertex.

Let \mathcal{F} denote the collection of graphs shown in Figure 6.2. In the following, we seek to find a structural characterization for graphs containing none of the 14 given graphs in \mathcal{F} as an induced subgraph.

Lemma 6.2.1. *Let G be a connected graph in $\mathcal{C}_{\leq 3}$, then G is \mathcal{F} -free.*

Proof. It follows by computing the fourth characteristic ideals of the graphs in \mathcal{F} and checking that they are trivial. Then, by Lemma 6.1.7, G cannot contain any graph in \mathcal{F} as induced subgraph. \square

Theorem 6.2.2. *A connected graph G is \mathcal{F} -free if and only if it is an induced subgraph of one of the following:*

- (1) C_5 ,
- (2) the triangular prism $K_3 \square K_2$,
- (3) a complete 4-partite graph,
- (4) $C_4^{\mathbf{r}}$, for some $-\mathbf{r} \in \mathbb{N}^4$, or
- (5) $S_4^{\mathbf{r}}$, for some $-\mathbf{r} \in \mathbb{N}^4$.

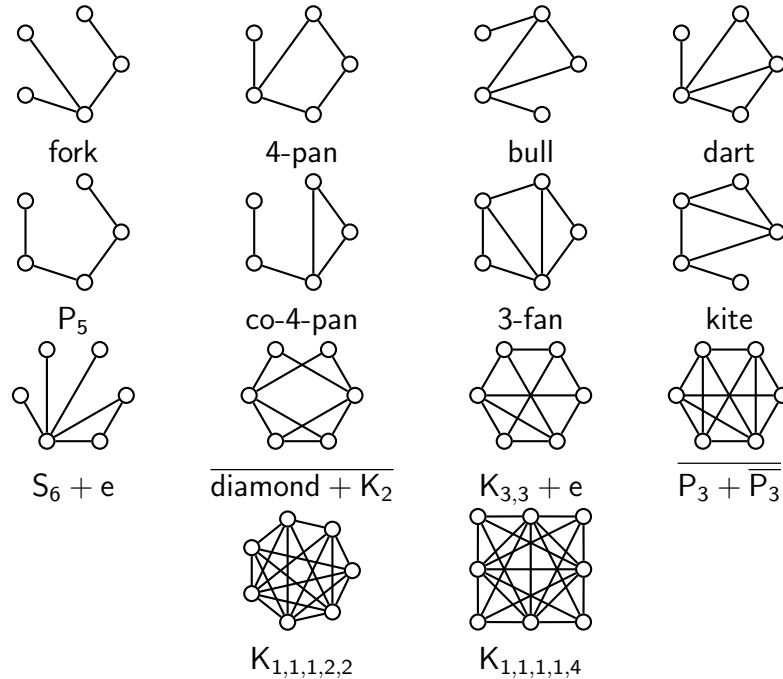
Figure 6.3: The family of graphs \mathcal{F} .

Proof. It is straightforward to verify that graphs of the forms specified can induce no subgraph from \mathcal{F} . Suppose henceforth that G is a connected \mathcal{F} -free graph; we show that G has one of the five forms described above.

Since G is connected, the well known result of Seinsche [86] states that G either contains P_4 as an induced subgraph, or G is the complement of a disconnected graph. Hence G is a join of two graphs with nonempty vertex sets.

Suppose first that G contains P_4 as an induced subgraph, and let w, x, y, z be the vertices, in order, of such an induced path.

Since G is $\{\text{fork}, \text{4-pan}, \text{bull}, \text{P}_5, \text{co-4-pan}, \text{3-fan}, \text{kite}\}$ -free, we conclude that any vertex of G not in $\{w, x, y, z\}$ is adjacent to either none of these four vertices, or it is adjacent to both endpoints w, z and at most one of the midpoints x, y . Hence we may partition the vertices of $G - \{w, x, y, z\}$ into three sets:

- V_{wz} : vertices adjacent to w, z and neither of x, y ;
- V_{wxz} : vertices adjacent to w, z and x but not y ;
- V_{wyz} : vertices adjacent to w, z and y but not x ;
- U : vertices adjacent to no vertex of $\{w, x, y, z\}$.

We illustrate these sets in Figure 6.2.

If there is a pair of non-adjacent vertices in V_{wz} then $G[\{w, y, z\} \cup V_{wz}]$ contains an induced copy of the **4-pan**. Moreover, if $|V_{wz}| \geq 2$ then $G[\{w, y, z\} \cup V_{wz}]$ contains an induced copy of the **dart**. Thus $|V_{wz}| \leq 1$.

Similarly, we have $|V_{wxz}| \leq 1$ and $|V_{wyz}| \leq 1$. If V_{wz} is nonempty, let us denote $V_{wz} = \{v_{wz}\}$ and so on.

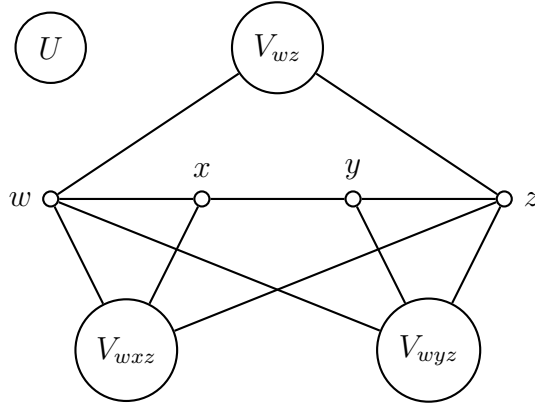
Figure 6.4: Diagram describing G .

Since the induced subgraph of G having vertex set $\{x, y, z, v_{wz}, v_{wxz}\}$ is not isomorphic to the **4-pan**, it must be the case that v_{wz} is adjacent to v_{wxz} . However, then the induced subgraph on $\{x, y, z, v_{wz}, v_{wxz}\}$ is isomorphic to the **kite**, a contradiction. Since a similar contradiction arises for vertices v_{wz} and v_{wyz} , we conclude that if V_{wz} is nonempty then both V_{wxz} and V_{wyz} are empty; if either V_{wxz} or V_{wyz} is nonempty, then V_{wz} is empty.

Let $E[A, B]$ be the set of edges between two sets of vertices A and B . If $E[V_{wxz}, V_{wyz}] \neq \emptyset$, then $G[\{w, x, z, v_{wxz}, v_{wyz}\}]$ contains the **3-fan** as an induced subgraph, a contradiction, so there are no edges between V_{wxz} and V_{wyz} .

Now note that if any vertex in U has a neighbor in V_{wz} , then G induces P_5 , a contradiction. If U has any neighbor in V_{wxz} (or in V_{wyz}), then G induces both **bull** and **4-pan**. Since G is connected, some vertex in U would have a neighbor in V_{wz} or V_{wxz} or V_{wyz} unless U were empty, so we conclude that U is empty.

We conclude that G is isomorphic to either P_4 , C_5 , the **house graph**, or the **triangular prism**. This completes the characterization of G when G induces P_4 .

Suppose henceforth that G is P_4 -free. As described previously, since G is a connected P_4 -free graph, then G can be written as $G = G_1 \vee G_2$, where G_1 and G_2 each have at least one vertex. Not every such graph is \mathcal{F} -free, as the graphs in Table 6.2 show.

If G is $K_2 + K_1$ -free, then, by Lemma 6.1.12, G is a complete multipartite graph. Since G is $\{K_{1,1,1,2,2}, K_{1,1,1,1,4}\}$ -free, if such a graph G has five or more partite sets, then no partite set can have four or more vertices, and at most one partite set can have two or three vertices. Thus, if G has five or more partite sets, then G is isomorphic to $3K_1 \vee K_m$ or to $2K_1 \vee K_m$ for some $m \geq 4$; which are included in the case (5).

If G contains $K_2 + K_1$, it must do so within G_1 or within G_2 . Without loss of generality, suppose that G_2 contains $K_2 + K_1$, and assume that G_2 cannot be written as a join of smaller graphs (if it could, we could redefine G_1 to include one of the vertex sets of this join). The forbidden subgraph assumptions imply that G_1 must be $\{P_3, 3K_1\}$ -free. Since G_1 is P_3 -free, it is a disjoint union of cliques. And since G_1 is $3K_1$ -free, there are at most two of these cliques. Hence G_1 has the form $K_p + K_q$,

name	alternative name
dart	$K_1 \vee (P_3 + K_1)$
3-fan	$P_4 \vee K_1$
$S_6 + e$	$K_1 \vee (K_2 + 3K_1)$
$\overline{\text{diamond}} + K_2$	$2K_1 \vee (K_2 + 2K_1)$
$K_{3,3} + e$	$3K_1 \vee (K_2 + K_1)$
$\overline{P_3} + \overline{P_3}$	$P_3 \vee (K_2 + K_1) = K_{1,2} \vee (K_2 + K_1)$
$K_{1,1,1,2,2}$	$K_3 \vee C_4$
$K_{1,1,1,1,4}$	$K_4 \vee 4K_1$

Table 6.1: Graphs in \mathcal{F} that are join of two graphs.

where $0 \leq p \leq q$ and $q \geq 1$ (by our assumption that the join $G = G_1 \vee G_2$ was nontrivial).

If $p \geq 1$ and $q \geq 2$, then G_1 contains $K_2 + K_1$ as an induced subgraph, and exchanging the roles of G_1 and G_2 in the arguments above imply that G_2 has the form $K_{p'} + K_{q'}$ for $p' \geq 1$ and $q' \geq 2$ and henceforth $G = (K_p + K_q) \vee (K_{p'} + K_{q'})$; which is included in case (4).

Next, we will consider the cases when $p = 1, q = 1$ and when $p = 0$ in detail. First we establish some further structure for G_2 .

Consider an induced copy of $K_2 + K_1$ within G_2 , and let v be a vertex of G_2 not in this induced subgraph. Since G is $K_1 \vee (P_3 + K_1)$ -free, we may assume that G_2 is $\{P_4, P_3 + K_1\}$ -free. And this implies that if v is adjacent to one endpoint of the K_2 -component in the $K_2 + K_1$ -subgraph, then it must be adjacent to the other endpoint.

Let ab be the edge and let c be the isolated vertex in an induced subgraph isomorphic to $K_2 + K_1$. Let X_d be the set of vertices in G_2 adjacent to none of a, b, c ; let X_{ab} be the set of vertices in G_2 adjacent to both a and b but not c ; let X_c be the set of vertices in G_2 adjacent to c but not a and b ; and let X_{abc} be the set of vertices in G_2 adjacent to all of a, b, c .

Now, if $p = q = 1$, then, since G is $\{2K_1 \vee (K_2 + 2K_1)\}$ -free, we may also conclude that G_2 is $K_2 + 2K_1$ -free, which implies that X_d is empty. And X_{abc} is empty as well, this is because, otherwise, we would have $P_3 \vee (K_2 + K_1)$ as an induced subgraph of G . The vertex sets X_{ab} and X_c must be cliques, otherwise, G would contain a $K_1 \vee (P_3 + K_1)$ or a $2K_1 \vee (K_2 + 2K_1)$, respectively. And $E[X_{ab}, X_c]$ is empty, since otherwise G would contain P_4 as induced subgraph. Therefore, G_2 is the disjoint union of two cliques, that is, $G = 2K_1 \vee (K_r + K_s)$ with $r \geq 2$ and $s \geq 1$. Which is contained in case (4).

On the other hand, let us consider the case $p = 0$ and $q \geq 1$. Then $G_1 = K_q$ and $V(G_2) = \{a, b, c\} \cup X$, where $X = X_{ab} \cup X_{abc} \cup X_c \cup X_d$.

The sets X_{ab} and X_c are cliques, since otherwise $G_2[\{a, c\} \cup X_{ab}]$ and $G_2[\{a, c\} \cup X_c]$ would, respectively, contain an induced copy of $(P_3 + K_1)$. Also X_d is a clique, since otherwise G would contain an induced copy of $K_1 \vee (K_2 + 3K_1)$.

Furthermore $E[X_c, X_d] = \emptyset = E[X_{ab}, X_d]$, otherwise $G_2[\{b, c\} \cup X_c \cup X_d]$ or $G_2[\{b, c\} \cup X_{ab} \cup X_d]$ would contain an induced copy of $P_3 + K_1$, respectively. Likewise, $E[X_{ab}, X_c] = \emptyset$ since otherwise P_4 would be an induced subgraph of $G_2[\{b, c\} \cup X_{ab} \cup X_c]$.

Moreover, $E[X_{abc}, X_d]$ is of maximum size, that is, every vertex of X_{abc} is adjacent to every vertex of X_d , since otherwise $G_2[\{b, c\} \cup X_{abc} \cup X_d]$ would contain an induced copy of $P_3 + K_1$. Also $E[X_{abc}, X_{ab}]$ and $E[X_{abc}, X_c]$ are of maximum size because G_2 is P_4 -free.

By the argument above and our assumption that G_2 cannot be written as a join of smaller graphs we can conclude that $X_{abc} = \emptyset$.

Finally, if $p = 0$ then $G = K_q \vee (K_r + K_s + K_t)$, where $r \geq 2$, $q, s \geq 1$ and $t \geq 0$. Which is included in case (5). □

Lemma 6.2.3. *The third characteristic ideals of C_5 and $K_3 \square K_2$ are trivial and the fourth characteristic ideals of C_5 and $K_3 \square K_2$ are non trivial. In fact, $A_4(C_5, t) = \langle t^2 + t - 1 \rangle$ and $A_4(K_3 \square K_2, t) = \langle t + 2, 5 \rangle$.*

Observation 6.2.4. *In the following, let $L_m = (t + 1)I_m - J_m$. Note that, for any \mathbf{r} such that $-\mathbf{r} \in \mathbb{N}^4$, the 4-minors of the matrices $tl_{\mathbf{r}_1 + \mathbf{r}_2 + \mathbf{r}_3 + \mathbf{r}_4} - A(C_4^{\mathbf{r}})$ and $tl_{\mathbf{r}_1 + \mathbf{r}_2 + \mathbf{r}_3 + \mathbf{r}_4} - A(S_4^{\mathbf{r}})$ are contained in the 4-minors of the matrices*

$$tl_{16} - A\left(C_4^{(-4, -4, -4, -4)}\right) = \begin{bmatrix} L_4 & -J_4 & 0_4 & -J_4 \\ -J_4 & L_4 & -J_4 & 0_4 \\ 0_4 & -J_4 & L_4 & -J_4 \\ -J_4 & 0_4 & -J_4 & L_4 \end{bmatrix}$$

and

$$tl_{16} - A\left(S_4^{(-4, -4, -4, -4)}\right) = \begin{bmatrix} L_4 & -J_4 & -J_4 & -J_4 \\ -J_4 & L_4 & 0_4 & 0_4 \\ -J_4 & 0_4 & L_4 & 0_4 \\ -J_4 & 0_4 & 0_4 & L_4 \end{bmatrix},$$

respectively. Therefore,

$$A_4(C_4^{\mathbf{r}}, t) \subseteq A_4\left(C_4^{(-4, -4, -4, -4)}, t\right) \text{ and } A_4(S_4^{\mathbf{r}}, t) \subseteq A_4\left(S_4^{(-4, -4, -4, -4)}, t\right)$$

for every $-\mathbf{r}$ such that $\mathbf{r} \in \mathbb{N}^4$.

Lemma 6.2.5. *Let \mathbf{r} such that $-\mathbf{r} \in \mathbb{N}^4$. Then the fourth characteristic ideal of $C_4^{\mathbf{r}}$ is not trivial. Moreover, $A_4(C_4^{\mathbf{r}}, t) \subseteq \langle t + 1, 3 \rangle$.*

Proof. The Gröbner basis of the ideal generated by the 4-minors of the matrix $tl_{16} - A\left(C_4^{(-4, -4, -4, -4)}\right)$ is $\langle t + 1, 3 \rangle$, that is, $A_4\left(C_4^{(-4, -4, -4, -4)}, t\right) = \langle t + 1, 3 \rangle$. Hence, by the argument in Observation 6.2.4, we have that $A_4(C_4^{\mathbf{r}}, t) \subseteq \langle t + 1, 3 \rangle$ for any \mathbf{r} such that $-\mathbf{r} \in \mathbb{N}^4$. □

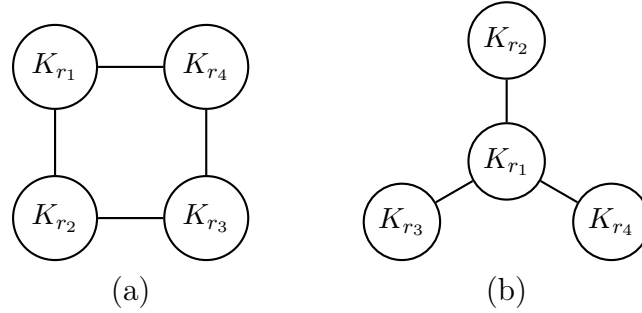

Figure 6.5: (a) is $C_4^{\mathbf{r}}$ and (b) is $S_4^{\mathbf{r}}$, for some \mathbf{r} such that $-\mathbf{r} \in \mathbb{N}^4$. An edge in these pictures denote that every vertex at an end is connected to every vertex at the other end.

Note that $A_4(C_4^{\mathbf{r}}, t) = \langle t + 1, 3 \rangle$ and $A_3(C_4^{\mathbf{r}}, t) = \langle 1 \rangle$ when $\mathbf{r}_1, \mathbf{r}_2, \mathbf{r}_3, \mathbf{r}_4 \leq -4$. In a similar manner, given that the Gröbner basis of $A_4\left(S_4^{(-4, -4, -4, -4)}, t\right)$ is $\langle t + 1, 2 \rangle$, we have the following

Lemma 6.2.6. *Let \mathbf{r} such that $-\mathbf{r} \in \mathbb{N}^4$. Then the fourth characteristic ideal of $S_4^{\mathbf{r}}$ is not trivial. Moreover, $A_4(S_4^{\mathbf{r}}, t) \subseteq \langle t + 1, 2 \rangle$.*

Theorem 6.2.7. *A connected graph G is in $\mathcal{C}_{\leq 3}$ if and only if it is an induced subgraph of one of the following:*

- (1) C_5 ,
- (2) the triangular prism $K_3 \square K_2$,
- (3) a complete 4-partite graph,
- (4) $C_4^{\mathbf{r}}$, for some \mathbf{r} such that $-\mathbf{r} \in \mathbb{N}^4$, or
- (5) $S_4^{\mathbf{r}}$, for some \mathbf{r} such that $-\mathbf{r} \in \mathbb{N}^4$.

Proof. \Rightarrow) This follows from Lemma 6.2.1 and Theorem 6.2.2.

\Leftarrow) From Lemmas 6.1.11, 6.2.3, 6.2.5 and 6.2.6, we have that the 4-th characteristic ideals of the graphs C_5 , $K_3 \square K_2$, complete 4-partite graphs, $C_4^{\mathbf{r}}$ and $S_4^{\mathbf{r}}$ are not trivial. Then, by Lemma 6.1.7, the 4-th characteristic ideal of any induced subgraph of these graphs is non-trivial. \square

Now, let us show the characterization of the regular graphs whose sandpile group has at most 3 trivial invariant factors.

Corollary 6.2.8. *Let G be a connected simple regular graph. Then $G \in \mathcal{K}_{\leq 3}$ if and only if G is one of the following:*

- (a) C_5 ,
- (b) $K_3 \square K_2$,

- (c) a complete graph K_r ,
- (d) a regular complete bipartite graph $K_{r,r}$,
- (e) a regular complete tripartite graph $K_{r,r,r}$,
- (f) a regular complete graph 4-partite graph $K_{r,r,r,r}$,
- (g) $C_4^{(-r,-r,-r,-r)}$, for any $r \in \mathbb{N}$.

Proof. \Rightarrow) This follows from the fact that G is a regular graph in $\mathcal{C}_{\leq 3}$.

\Leftarrow) It is clear from Lemma 6.2.3 that the fourth invariant factors of C_5 and $K_3 \square K_2$ are different than 1. The graphs in (c), (d) and (e) are precisely the graphs in $\mathcal{K}_{\leq 2} \subset \mathcal{K}_{\leq 3}$. For (f), if $r = 1$ we have the complete graph with four vertices. Therefore, we assume that $r \geq 2$. By Lemma 6.1.11, the fourth characteristic ideal of a 4-partite regular complete graph is $\langle 3, t \rangle$ and its third characteristic ideal is trivial. Then, evaluating at $t = 3r$, the degree of any vertex, we have that the fourth invariant factor is $\gcd(3, 3r) = 3$ and therefore $K_{r,r,r,r} \in \mathcal{K}_{\leq 3}$. Finally, for (g), note that the degree of any vertex of $C_4^{(-r,-r,-r,-r)}$ is $3r - 1$. By Lemma 6.2.5, when $r \geq 4$ the fourth invariant factor is the $\gcd(3r, 3) = 3$. Thus $C_4^{(-r,-r,-r,-r)} \in \mathcal{K}_{\geq 3}$ when $r \geq 4$. For $r < 4$, we can do the explicit computations to verify that $C_4^{(-r,-r,-r,-r)} \in \mathcal{K}_{\leq 3}$. \square

6.3. Graphs whose Smith group has at most 4 invariant factors equal to 1

In this section we show the characterizations of the graph families $\mathcal{S}_{\leq k}$ for $k \in \{1, 2, 3\}$. And for $k = 4$, we present a set of 43 minimal forbidden graphs for $\mathcal{S}_{\leq 4}$.

We have that $\mathcal{S}_{\leq k}$ is closed under induced subgraphs. This observation follows from next proposition.

Proposition 6.3.1. *If H is an induced subgraph of G , then $\delta_1(A(H)) \leq \delta_1(A(G))$.*

Proof. Let H be an induced subgraph of G . For any k such that $1 \leq k \leq |V(H)|$, the k -minors of $A(H)$ are contained in the k -minors of $A(G)$. Therefore, if $\Delta_k(A(H)) = 1$, then $\Delta_k(A(G)) = 1$. \square

Given a family \mathcal{F} of graphs, a graph G is called \mathcal{F} -free if no induced subgraph of G is isomorphic to a member of \mathcal{F} . We can define a graph G to be *forbidden* for $\mathcal{S}_{\leq k}$ when $\delta_1(A(G)) \geq k + 1$. Let $\text{Forb}(\mathcal{S}_{\leq k})$ denote the set of minimal forbidden graphs for $\mathcal{S}_{\leq k}$ with respect to the induced subgraph order. Thus $G \in \mathcal{S}_{\leq k}$ if and only if G is $\text{Forb}(\mathcal{S}_{\leq 2})$ -free. Therefore, characterizing the minimal forbidden induced subgraphs for $\mathcal{S}_{\leq k}$ leads to a characterization of $\mathcal{S}_{\leq k}$. For instance, let P_2 denote the path with 2 vertices. We have that the Smith normal form of the adjacency matrix of P_2 has 2 invariant factors equal to 1. Then, $\mathcal{S}_{\leq 1}$ consists only of K_1 , and there is no graph G with $\delta_1(A(G)) = 1$.

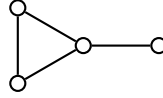

Figure 6.6: paw graph

Now, we are going to give an alternative proof of the characterization $\mathcal{S}_{\leq 2}$. For this, the following result gives the SNF for complete k -partite graphs. A particular case of Lemma 6.1.11 is the following lemma, which also was noticed in [20].

Lemma 6.3.2. *Let G be a complete k -partite graph with n vertices. Then the Smith normal form of $A(G)$ is equal to $I_{k-1} \oplus (k-1) \oplus 0I_{n-k}$.*

Now we are ready to give the characterization of graphs whose Smith group have at most 2 invariant factors.

Theorem 6.3.3. *Let G be connected graph. Then the followings are equivalent.*

1. the SNF of $A(G)$ has at most 2 invariant factors equal to 1,
2. G is $\{P_4, \text{paw}, K_4\}$ -free,
3. G is an induced subgraph of a complete tripartite graph.

Proof. (1) \implies (2) The SNF of the adjacency matrices of P_4 , paw, K_4 are equal to $\text{Diag}(1, 1, 1, 1)$, $\text{Diag}(1, 1, 1, 1)$ and $\text{Diag}(1, 1, 1, 3)$, respectively. Since any induced subgraph H of P_4 , paw, or K_4 has $\delta_1(A(H)) \leq 2$, then $\{P_4, \text{paw}, K_4\} \subseteq \text{Forb}(\mathcal{S}_{\leq 2})$.

(2) \implies (3) By Lemma 6.1.12, G is either triangle free or a complete multipartite graph. In the first case by Lemma 6.1.13, G is a complete bipartite graph. And in the second case since G is K_4 -free, then G is complete tripartite graph.

(3) \implies (1) It follows by Lemma 6.3.2 that the SNF of $A(G)$ is at most 2. \square

An analogous reasoning give us the characterization of $\mathcal{S}_{\leq 3}$.

Theorem 6.3.4. *Let G be connected graph. Then the followings are equivalent.*

1. the SNF of $A(G)$ has at most 3 invariant factors equal to 1
2. G is $\{P_4, \text{paw}, K_5\}$ -free
3. G is an induced subgraph of a complete four-partite graph

Proof. (1) \implies (2) The SNF of the adjacency matrices of P_4 , paw, K_5 are equal to $\text{Diag}(1, 1, 1, 1)$, $\text{Diag}(1, 1, 1, 1)$ and $\text{Diag}(1, 1, 1, 1, 4)$, respectively. Since any induced subgraph H of P_4 , paw, or K_5 has $\delta_1(A(H)) \leq 3$, then $\{P_4, \text{paw}, K_5\} \subseteq \text{Forb}(\mathcal{S}_{\leq 3})$.

(2) \implies (3) Since G is paw-free, then by Lemma 6.1.12, G is either triangle-free or a complete multipartite graph. Thus, in the first case, G is also K_3 -free, by Lemma 6.1.13, G is a complete bipartite graph. In the second case, since G is K_5 -free, then G is complete tripartite graph.

(3) \implies (1) It follows by Lemma 6.3.2 that the SNF of $A(G)$ is at most 3. \square

The next case is more complicated. With the use of SAGE [85], we found that there are at least 43 forbidden graphs for $\mathcal{S}_{\leq 4}$, see Figure 6.7.



Figure 6.7: Some forbidden for $\mathcal{S}_{\leq 4}$.

The following SAGE code computes the minimal forbidden graphs with at most m vertices for $\mathcal{S}_{\leq n}$.

```

1 def MinForb(m,n):
2     Forbidden = []
3     for k in range(2,m):
4         for g in graphs(k):
5             if g.is_connected():
6                 SNF = g.adjacency_matrix().elementary_divisors()
7                 num_ones = list(SNF).count(1)
8                 if num_ones >= n+1:
9                     Forbidden.append([g.graph6_string(),num_ones])

```

```

10 Minimal = []
11 for g in range(0,len(Forbidden)):
12     flag = True
13     for h in Minimal:
14         if Graph(Forbidden[g][0]).subgraph_search(Graph(h),induced=True) !=
15             None:
16                 flag = False
17                 break
18     if flag == True:
19         Minimal.append(Forbidden[g][0])
20 return Minimal

```

The problem of characterizing graphs in $\mathcal{S}_{\leq 4}$ is not straightforward. However, it is interesting that if $G \in \mathcal{S}_{\leq 4}$, then any graph obtained by replacing its vertices by stable sets will be also in $\mathcal{S}_{\leq 4}$. This will be shown next.

Lemma 6.3.5. *For any $\mathbf{d} \in \mathbb{N}^V$, the non-zero invariant factors of $A(G)$ are equal to the non-zero invariant factors of $A(G^{\mathbf{d}})$.*

Proof. Given $u \in V$. Let G^u denote the graph obtained after duplicating vertex u . Since the adjacency matrix of G^u is equivalent to $\begin{bmatrix} A(G) & \mathbf{0}^T \\ \mathbf{0} & 0 \end{bmatrix}$, then the non-zero invariant factors of $A(G)$ and $A(G^u)$ are the same. From which the result follows. \square

Previous lemma help us in computing the Smith normal form of the adjacency matrix of graphs with duplicated vertices. In particular, it bound the number of non-zero invariant factors.

Corollary 6.3.6. *Let G be a graph in $\mathcal{S}_{\leq k}$, then $G^{\mathbf{d}} \in \mathcal{S}_{\leq k}$ for any $\mathbf{d} \in \mathbb{N}^V$.*

Conclusions

In this thesis we first studied the concept of arithmetical structures. In particular we focused on its algorithmic aspects. Regarding this the main result is that

- There exists an algorithm that computes all arithmetical structures of an irreducible non-negative integer matrix.

Moreover, we studied a more general scenario for this problem. We define the arithmetical structures of a dominated polynomial and proved that

- There exists an algorithm that computes all arithmetical structures of an irreducible dominated polynomial.

Another topic studied in this work was the determinantal ideals of graphs and their applications to some problems in algebraic graph. With respect to this the main results are the following:

- A combinatorial description of the algebraic structure of the sandpile groups of outerplanar graphs. Based on the critical ideals of their weak (plane) duals.
- A complete characterization of the set of regular graphs whose sandpile group has at most three trivial invariant factors. In order to do this we describe the set of graphs with at most three trivial characteristic ideals.

Future work: For arithmetical structures: properly define and analyze the arithmetical structures of skew-symmetric matrices and moreover, for signed graphs; study how the arithmetical structures of a graph change under certain graph operations; and to give an explicit algorithm that solves the Hilbert's tenth problem for dominated polynomials.

For determinantal ideals: to continue classifying the sets of graphs with few trivial determinantal ideals. Which can lead to other interesting applications.

Bibliography

- [1] Aida Abiad and Carlos A. Alfaro. «Enumeration of cospectral and coinvariant graphs». In: *Applied Mathematics and Computation* 408 (2021), p. 126348.
- [2] Aida Abiad, Carlos A. Alfaro, Kristin Heysse, and Marcos C. Vargas. «Eigenvalues, Smith normal form and determinantal ideals». arXiv:1910.12502. 2019.
- [3] William W. Adams and Philippe Loustau. *An introduction to Gröbner Bases*. Graduate Studies in Mathematics, vol. 3. AMS, 1994.
- [4] Carlos A. Alfaro. «On graphs with 2 trivial distance ideals». In: *Linear Algebra and its Applications* 597 (2020), pp. 69–85.
- [5] Carlos A. Alfaro, Michael D. Barrus, John Sinkovic, and Ralihe R. Villagrán. «Graphs with few trivial characteristic ideals». In: *Linear Algebra and its Applications* 615 (2021), pp. 155–174.
- [6] Carlos A. Alfaro, Hugo Corrales, and Carlos E. Valencia. «Critical ideals of signed graphs with twin vertices». In: *Advances in Applied Mathematics* 86 (2017), pp. 99–131.
- [7] Carlos A. Alfaro and Jephian C.-H. Lin. «Critical ideals, minimum rank and zero forcing number». In: *Applied Mathematics and Computation* 358 (2019), pp. 305–313.
- [8] Carlos A. Alfaro and Libby Taylor. «Distance ideals of graphs». In: *Linear Algebra and its Applications* 584 (2020), pp. 127–144.
- [9] Carlos A. Alfaro and Carlos E. Valencia. «On the sandpile group of the cone of a graph». In: *Linear Algebra and its Applications* 436.5 (2012), pp. 1154–1176.
- [10] Carlos A. Alfaro and Carlos E. Valencia. «Graphs with two trivial critical ideals». In: *Discrete Applied Mathematics* 167 (2014), pp. 33–44.
- [11] Carlos A. Alfaro and Carlos E. Valencia. «Small clique number graphs with three trivial critical ideals». In: *Special Matrices* 6.1 (2018), pp. 122–154.
- [12] Carlos A. Alfaro, Carlos E. Valencia, and Marcos C. Vargas. «Computing sandpile configurations using integer linear programming». arXiv:2008.13672. 2020.
- [13] Carlos A. Alfaro, Carlos E. Valencia, and Adrián Vázquez-Ávila. «Digraphs with at most one trivial critical ideal». In: *Linear and Multilinear Algebra* 66.10 (2018), pp. 2036–2048.

- [14] Carlos A. Alfaro and Ralihe R. Villagrán. «The structure of sandpile groups of outerplanar graphs». In: *Applied Mathematics and Computation* 395 (2021), p. 125861.
- [15] Allen Altman and Steven Kleiman. *A Term of Commutative Algebra*. Worldwide Center of Mathematics, version of September 3, 2012.
- [16] Kassie Archer, Abigail C. Bishop, Alexander Diaz-Lopez, Luis D. García Puente, Darren Glass, and Joel Louwsma. «Arithmetical structures on bidents». In: *Discrete Mathematics* 343.7 (2020), p. 111850.
- [17] Roland Bacher, Pierre de La Harpe, and Tatiana Nagnibeda. «The lattice of integral flows and the lattice of integral cuts on a finite graph». en. In: *Bulletin de la Société Mathématique de France* 125.2 (1997), pp. 167–198.
- [18] Per Bak, Chao Tang, and Kurt Wiesenfeld. «Self-organized criticality». In: *Physical Review A (3)* 38.1 (1988), pp. 364–374.
- [19] Ravindra B. Bapat. *Graphs and Matrices*. Second. Universitext. 2014.
- [20] Ravindra B. Bapat and Masoud Karimi. «Integral complete multipartite graphs». In: *Linear Algebra and its Applications* 549 (2018), pp. 1–11.
- [21] Wayne Barrett, Hein van der Holst, and Raphael Loewy. «Graphs whose minimal rank is two». In: *Electron. J. Linear Algebra* 11 (2004), pp. 258–280.
- [22] Ryan Becker and Darren B. Glass. «Cyclic critical groups of graphs». In: *Australasian Journal of Combinatorics* 64 (2016), pp. 366–375.
- [23] Andrew Berget, Andrew Manion, Molly Maxwell, Aaron Potechin, and Victor Reiner. «The Critical Group of a Line Graph». In: *Annals of Combinatorics* 16 (2012), pp. 449–488.
- [24] Abraham Berman and Robert J. Plemmons. *Nonnegative matrices in the mathematical sciences*. Vol. 9. Classics in Applied Mathematics. Revised reprint of the 1979 original. Society for Industrial and Applied Mathematics (SIAM), Philadelphia, PA, 1994.
- [25] Kenneth A. Berman. «Bicycles and spanning trees». In: *SIAM Journal on Algebraic Discrete Methods* 7 (1986), pp. 1–12.
- [26] Norman L. Biggs. «Chip-firing and the critical group of a graph.» In: *Journal of Algebraic Combinatorics* 9 (1999), pp. 25–46.
- [27] Miklós Bóna. *A Walk Through Combinatorics*. Fourth. World Scientific, 2016.
- [28] J.A. Bondy and U.S.R. Murty. «Graph Theory». In: Graduate Texts in Mathematics 244 (2008).
- [29] Benjamin Braun, Hugo Corrales, Scott Corry, Luis David García Puente, Darren Glass, Nathan Kaplan, Jeremy L. Martin, Gregg Musiker, and Carlos E. Valencia. «Counting arithmetical structures on paths and cycles». In: *Discrete Mathematics* 341.10 (2018), pp. 2949–2963.

- [30] Jane Breen, Steve Butler, Melissa Fuentes, Bernard Lidický, Michael Phillips, Alexander W. N. Riasanovksy, Sung-Yell Song, Ralihe R. Villagrán, Cedar Wiseman, and Xiaohong Zhang. «Hadamard diagonalizable graphs of order at most 36». arXiv:2007.09235. 2020.
- [31] Andries E. Brouwer and Willem H. Haemers. *Spectra of graphs*. Springer Science & Business Media, 2011.
- [32] David B. Chandler, Peter Sin, and Qing Xiang. «The Smith group of the hypercube graph». In: *Designs, Codes and Cryptography* 84 (2017), pp. 283–294.
- [33] Haiyan Chen and Bojan Mohar. «The sandpile group of a polygon flower». In: *Discrete Applied Mathematics* 270 (2019), pp. 68–82.
- [34] Sheng Chen and Sheng Kui Ye. «Critical groups for homeomorphism classes of graphs». In: *Discrete Mathematics* 309.1 (2009), pp. 255–258.
- [35] Hans Christianson and Victor Reiner. «The critical group of a threshold graph». In: *Linear Algebra and its Applications* 349.1 (2002), pp. 233–244.
- [36] Fan R. K. Chung. *Spectral Graph Theory*. American Mathematical Society, 1997.
- [37] Julien Clancy, Nathan Kaplan, Timothy Leake, Sam Payne, and Melanie Matchett Wood. «On a Cohen—Lenstra Heuristic for Jacobians of Random Graphs». In: *Journal of Algebraic Combinatorics* 42.3 (Nov. 2015), pp. 701–723.
- [38] Francesc Comellas, Alícia Miralles, Hongxiao Liu, and Zhongzhi Zhang. «The number of spanning trees of an infinite family of outerplanar, small-world and self-similar graphs». In: *Physica A: Statistical Mechanics and its Applications* 392.12 (2013), pp. 2803–2806.
- [39] Robert Cori and Dominique Rossin. «On the Sandpile Group of Dual Graphs». In: *European Journal of Combinatorics* 21.4 (2000), pp. 447–459.
- [40] Hugo Corrales and Carlos E. Valencia. «On the critical ideals of graphs». In: *Linear Algebra and its Applications* 439.12 (2013), pp. 3870–3892.
- [41] Hugo Corrales and Carlos E. Valencia. «Critical ideals of trees». arXiv:1504.06239. 2017.
- [42] Hugo Corrales and Carlos E. Valencia. «Arithmetical structures on graphs». In: *Linear Algebra and its Applications* 536 (2018), pp. 120–151.
- [43] Hugo Corrales and Carlos E. Valencia. «Arithmetical structures on graphs with connectivity one». In: *Journal of Algebra and Its Applications* 17.08 (2018), p. 1850147.
- [44] Scott Corry and David Perkinson. *Divisors and Sandpiles: An Introduction to Chip-Firing*. American Mathematical Society, Providence, RI, 2018.
- [45] Martin Davis, Yuri V. Matiyasevich, and Julia Robinson. «Hilbert’s tenth problem. Diophantine equations: positive aspects of a negative solution». In: *Proceedings of Symposia in Pure Mathematics* 28 (1976), pp. 323–378.

- [46] Leonard E. Dickson. «Finiteness of the Odd Perfect and Primitive Abundant Numbers with n Distinct Prime Factors». In: *American Journal of Mathematics* 35 (1913), pp. 413–422.
- [47] Reinhard Diestel. *Graph theory*. Fifth. Vol. 173. Graduate Texts in Mathematics. Springer-Verlag Berlin Heidelberg, 2017.
- [48] Joshua E. Ducey, Jonathan Gerhard, and Noah Watson. «The Smith and Critical Groups of the Square Rook’s Graph and its Complement.» In: *Electronic Journal of Combinatorics* 23.P4.9 (4 2016).
- [49] Joshua E. Ducey and Deelan M. Jalil. «Integer invariants of abelian Cayley graphs». In: *Linear Algebra and its Applications* 445 (2014), pp. 316–325.
- [50] David Eisenbud. *Commutative Algebra with a view toward Algebraic Geometry*. Graduate Texts in Mathematics 150, Springer-Verlag, 1995.
- [51] Kirsten Eisenträger, Russell Miller, Jennifer Park, and Alexandra Shlapentokh. «As easy as \mathbb{Q} : Hilbert’s tenth problem for subrings of the rationals and number fields». In: *Transactions of the American Mathematical Society* 369 (2017), pp. 8291–8315.
- [52] Herbert J. Fleischner, Dennis P. Geller, and Frank Harary. «Outerplanar Graphs and Weak Duals». In: *The Journal of the Indian Mathematical Society* 38.1-4 (1974), pp. 215–219. ISSN: 2455-6475. URL: <http://www.informaticsjournals.com/index.php/jims/article/view/16694>.
- [53] Yibo Gao. «On the critical ideals of complete multipartite graphs». In: *Electronic Journal of Linear Algebra* 36 (2020), pp. 94–105.
- [54] Darren B. Glass and Joshua Wagner. «Arithmetical Structures on Paths With a Doubled Edge». arXiv:1903.01398. 2019.
- [55] Chris Godsil and Gordon F. Royle. *Algebraic Graph Theory*. Vol. 207. Graduate Texts in Mathematics. Springer, New York, NY, 2021.
- [56] Robert Grone, Russell Merris, and William Watkins. «Laplacian Unimodular Equivalence of Graphs». In: *Combinatorial and Graph-Theoretical Problems in Linear Algebra*. Ed. by Richard A. Brualdi, Shmuel Friedland, and Victor Klee. New York, NY: Springer New York, 1993, pp. 175–180.
- [57] Johnny Guzmán and Caroline J. Klivans. «Chip-firing and energy minimization on M -matrices». In: *Journal of Combinatorial Theory, Series A* 132 (2015), pp. 14–31.
- [58] Zachary Harris and Joel Louwsma. «On Arithmetical Structures on Complete Graphs». In: *involve* 13 (2020), pp. 345–355.
- [59] Yao P. Hou, Wai C. Shiu, and Wai H. Chan. «Graphs whose critical groups have larger rank». In: *Acta Mathematica Sinica, English Series* 27 (2011), pp. 1663–1670.
- [60] OEIS Foundation Inc. *The On-Line Encyclopedia of Integer Sequences*. URL: <http://oeis.org/A002967>.

- [61] Brian Jacobson, Andrew Niedermaier, and Victor Reiner. «Critical groups for complete multipartite graphs and Cartesian products of complete graphs». In: *Journal of Graph Theory* 44.3 (2003), pp. 231–250.
- [62] Nathan Jacobson. *Basic Algebra I*. second. New York, USA: W. H. Freeman and Company, 1985.
- [63] Charles R. Johnson and Carlos M. Saiago. «Estimation of the maximum multiplicity of an eigenvalue in terms of the vertex degrees of the graph of a matrix». In: *Electronic Journal of Linear Algebra* 9.3 (2002), pp. 27–31.
- [64] Hans Kellerer, Ulrich Pferschy, and David Pisinger. *Knapsack Problems*. Springer-Verlag Berlin Heidelberg, 2004.
- [65] Christopher Keyes and Tomer Reiter. «Bounding the number of arithmetical structures on graphs». In: *Discrete Mathematics* 344.9 (2021), p. 112494.
- [66] Caroline J. Klivans. *The Mathematics of Chip-firing*. 1st ed. Chapman and Hall/CRC., 2018.
- [67] I.A. Krepkiy. «The Sandpile Groups of Chain-Cyclic Graphs». In: *Journal of Mathematical Sciences* 200 (2014), pp. 698–709.
- [68] Lionel Levine. «The sandpile group of a tree». In: *European Journal of Combinatorics* 30.4 (2009), pp. 1026–1035.
- [69] Lionel Levine. «Sandpile groups and spanning trees of directed line graphs». In: *Journal of Combinatorial Theory, Series A* 118.2 (2011), pp. 350–364.
- [70] Yunhua Liao, Aixiang Fang, and Yaoping Hou. «The Tutte polynomial of an infinite family of outerplanar, small-world and self-similar graphs». In: *Physica A: Statistical Mechanics and its Applications* 392.19 (2013), pp. 4584–4593.
- [71] Dino J. Lorenzini. «Arithmetical graphs». In: *Mathematische Annalen* 285.3 (1989), pp. 481–501.
- [72] Dino J. Lorenzini. «A finite group attached to the laplacian of a graph». In: *Discrete Mathematics* 91.3 (1991), pp. 277–282.
- [73] Dino J. Lorenzini. «Smith normal form and Laplacians». In: *Journal of Combinatorial Theory, Series B* 98.6 (2008), pp. 1271–1300.
- [74] Yuri V. Matiyasevich. *Hilbert’s tenth problem*. MIT Press., 1993.
- [75] Criel Merino. «The chip-firing game». In: *Discrete Mathematics* 302.1 (2005). Structural Combinatorics, pp. 188–210.
- [76] Russell Merris. «Unimodular equivalence of graphs». In: *Linear Algebra and its Applications* 173 (1992), pp. 181–189.
- [77] Gregg Musiker. «The critical groups of a family of graphs and elliptic curves over finite fields». In: *Journal of Algebraic Combinatorics* 30 (2009), pp. 255–276.
- [78] Stephan Olariu. «Paw-free graphs». In: *Information Processing Letters* 28.1 (1988), pp. 53–54.

- [79] Yong-Liang Pan and Jian Wang. «A note on the third invariant factor of the Laplacian matrix of a graph». In: *Journal of University of Science and Technology of China* 6 (2011), pp. 471–476.
- [80] David Perkinson, Nick Salter, and Tianyuan Xu. «A Note on the Critical Group of a Line Graph». In: *Electronic Journal of Combinatorics* 18 (2011).
- [81] Caitlin R. Phifer. «The Cycle Intersection Matrix and Applications to Planar Graphs and Data Analysis for Postsecondary Mathematics Education, Thesis (Ph.D.)» 2014, 73 pp. URL: https://digitalcommons.uri.edu/oa_diss/210.
- [82] Bjorn Poonen. «Hilbert’s Tenth Problem and Mazur’s Conjecture for Large Subrings of \mathbb{Q} ». In: *Journal of the American Mathematical Society* 16.4 (2003), pp. 981–990.
- [83] Julia Robinson. «Definability and decision problems in arithmetic». In: *Journal of Symbolic Logic* 14.2 (1949), pp. 98–114.
- [84] Joseph J. Rushanan. «Topics in integral matrices and abelian group codes [dissertation]». 1986.
- [85] The Sage Developers. *SageMath, the Sage Mathematics Software System (Version 9.0)*. <https://www.sagemath.org>. 2020.
- [86] D. Seinsche. «On a property of the class of n -colorable graphs». In: *Journal of Combinatorial Theory, Series B* 16.2 (1974), pp. 191–193.
- [87] Nigel P. Smart. *The Algorithmic Resolution of Diophantine Equations: A Computational Cookbook*. London Mathematical Society Student Texts. Cambridge University Press, 1998.
- [88] Richard P. Stanley. «Smith normal form in combinatorics». In: *Journal of Combinatorial Theory, Series A* 144 (2016). Fifty Years of the Journal of Combinatorial Theory, pp. 476–495.
- [89] Evelin Toumpakari. «On the sandpile group of regular trees». In: *European Journal of Combinatorics* 28.3 (2007), pp. 822–842.
- [90] Carlos E. Valencia and Ralihe R. Villagrán. «Algorithmic aspects of arithmetical structures». arXiv:2101.05238. 2021.
- [91] Ralihe R. Villagrán. *Arithmetical_Structures, GitHub repository. GitHub*. https://github.com/Ralihe/Arithmetical_Structures. 2021.
- [92] Andrew Vince. «Elementary Divisors of Graphs and Matroids». In: *European Journal of Combinatorics* 12.5 (1991), pp. 445–453.
- [93] David G. Wagner. «The critical group of a directed graph». arXiv:math/0010241. 2000.
- [94] William Watkins. «The laplacian matrix of a graph: unimodular congruence». In: *Linear and Multilinear Algebra* 28.1-2 (1990), pp. 35–43.
- [95] Gerald Williams. «Smith forms for adjacency matrices of circulant graphs». In: *Linear Algebra and its Applications* 443 (2014), pp. 21–33.

- [96] Melanie M. Wood. «The distribution of sandpile groups of random graphs». In: *Journal of the American Mathematical Society* 30 (2017), pp. 915–958.

Index of symbols

- $A(G)$, 15
 $A[\mathcal{I}; \mathcal{J}]$, 23
 $A_k(G, t)$, 25
 $B(G)$, 15
 C_n , 12
 $F(C_i; PC_{n_1}, \dots, PC_{n_l})$, 78
 $G \vee H$, 13
 $G^{\mathbf{d}}$, 94
 $I_k(M)$, 24
 $I_i(G, X_G)$, 25
 $K(G)$, 17
 $K(G, \mathbf{d}, \mathbf{r})$, 21
 K_n , 12
 K_{m_1, m_2, \dots, m_k} , 13
 $L(G)$, 15
 $L(G, X_G)$, 25
 PL_n^k , 77
 P_n , 12
 $S(G)$, 19
 S_n , 12
 T^l , 73
 X_G , 1
 \mathbb{N} , 13
 \mathbb{N}_+ , 13
 \mathbb{Z} , 13
 \mathbf{deg}_G , 11
 $\mathcal{A}(G)$, 21
 $\mathcal{A}(L)$, 33
 $\text{coker}(L)$, 16
 $\delta_1(G)$, 68
 $\gamma(G)$, 25
 γ_A , 25
 $\kappa(G)$, 68
 $\text{MIP}[X]$, 50
 $\mathbb{M}(G)$, 16
 $\mathbb{Z}[X]$, 24
 $\mathbb{Z}[X]^*$, 50
 $\mathcal{C}(M)$, 39
 $\mathcal{C}_{\leq k}$, 91
 $\mathcal{D}(L)$, 33
 $\mathcal{D}(f)$, 54
 $\mathcal{D}_{\geq 0}(L)$, 32
 $\mathcal{D}_{\geq 0}(f)$, 55
 \mathcal{F}_f , 53
 $\mathcal{G}(M)$, 16
 \mathcal{K}_k , 87
 \overline{G} , 13
 $\tau(G)$, 18
 ${}_2F_1(a, b; c; x)$, 77
 ${}_2\text{Mat}(T^l, k)$, 73
 $d_G(u, v)$, 12
 $f_{L, \mathbf{d}}(X)$, 39
 $\text{minors}_i(L)$, 17
 ${}_2\text{Mat}^*(T^l)$, 73
 $\text{HTP}(R)$, 51
 $\text{stab}(\mathbf{c})$, 20

Index

- 2-matching, 7
- algebraic co-rank, 25
- arithmetical structure, 21
 - of a dominated polynomial, 54
 - of a graph, 21
 - of a non-negative integer matrix, 33
- catalan numbers, 21
- chip configuration, 19
- chip firing process, 19
- clique, 13
- cokernel, 16
- critical configuration, 20
- critical group, 17
- cycle, 12
- degree of a vertex, 11
- degree vector, 11
- disjoint union of graphs, 13
- dominated polynomial, 53
- equivalent matrices, 5
- Gröbner basis, 24
- graph, 11
 - biconnected, 14
 - complement, 13
 - complete multipartite, 13
 - cone, 13
 - connected, 12
 - cycle, 12
 - directed, 12
 - drawing, 11
 - Dual, 15
 - faces, 14
 - k-connected, 14
 - matrices, 16
 - minor, 14
 - orientation, 12
 - Outerplanar, 14
 - path, 12
 - Planar, 14
 - regular, 13
 - signed, 12
 - simple, 12
 - star, 12
 - subdivision, 14
 - topological minor, 14
 - weak dual, 15
 - weighted, 12
- hypergeometric function, 77
- ideal
 - characteristic, 25
 - critical, 25
 - determinantal, 24
- invariant factors, 17
 - trivial, 18
- join of graphs, 13
- length, 12

- M-matrix, 22
 - almost non-singular, 23
 - quasi, 32
 - quasi non-singular, 32
- matching, 12
 - perfect, 12
- matrix, 15
 - adjacency, 15
 - equivalent, 16
 - generalized Laplacian, 25
 - incidence, 15
 - Laplacian, 15
 - minor, 17
 - pseudo-Laplacian, 20
 - reduced Laplacian, 7, 20
 - singular, 23
- path, 12
- polygon chain, 76
- polygon flower, 78
- primitive vector, 20
- principal minor, 23
- principal submatrix, 23
- sandpile group, 17
- sink vertex, 19
- Smith group, 19
- Smith normal form, 17
- stable configuration, 19
- stable set, 13
- subgraph, 13
 - induced, 13
 - spanning, 13
- tree, 12
- underlying graph of a matrix, 16
- usual partial order of vector, 33
- walk, 12
- Z-matrix, 22